



2014

OFFICIAL RULES & REGULATIONS

RENEGADE DIVISION

NOTE: Rule changes from 2013 in ***RED ITALICS***

All cars participating in Devil's Bowl Speedway events **MUST** be equipped with a working *RACEceiver* one-way scanner unit and a working *MYLAPS* timing transponder.

RACEceiver website: www.raceceiver.com

MYLAPS website: www.mylaps.com

Sanctioned by:



Track Address: 2743 Route 22A, West Haven, VT 05743
Mailing Address: 261 Randbury Rd., Rutland, VT 05701
Phone: (802) 265-3112 | Email: devilsbowlspeedway@gmail.com
Website: www.devilsbowlspeedwayvt.com

WARRANTY DISCLAIMER

The rules promulgated in this rule book are intended as guidelines for the sport of stock car, auto racing or such racing competition, and the rules relating to the safety of equipment are the responsibility of each car owner, driver and crew member who participates in the sport of auto racing under these rules. No expressed or implied warranty of safety is intended nor may be inferred from the publication of these rules, nor the compliance therewith. Nothing herein should be construed as a guarantee against injury or death to participants, by-standers or spectators.

Specifications and rules set forth in this rule book are based upon the recommendations of competing members of other organizations and other participants in the sport of auto racing.

Devil's Bowl Speedway specifically states that it has not tested any equipment or use of equipment that it refers to in this rule book and makes no warranties either specific or implied with regard thereto and any use thereof must look to the manufacturer thereof with regard to said warranties.

To aid in the safety of participants in automobile stock car racing, as well as that of the spectators, and to provide for the orderly conduct of stock car racing events, requires close adherence to the rules and regulations set forth. It is the responsibility of each participant, car owner, driver and crew to make every possible effort to obey the safety rules both written and unwritten to assure the safety of all involved. Upon submitting your application for membership and your entering onto the grounds of Devil's Bowl Speedway you assume this responsibility personally.

© 2011-2014 Devil's Bowl Speedway, Bruno Properties, LLC. Any duplication, reproduction or other use of this rulebook must be approved in writing by Devil's Bowl Speedway, 261 Randbury Rd., Rutland, VT 05701

DEVIL'S BOWL SPEEDWAY MEMBERSHIP & PIT ADMITTANCE

1. All persons under 18 years of age MUST have a signed minor's release from a legal guardian and provide a copy of their birth certificate.
2. Any competitor (driver) under the age of 18 that has not competed in a prior year at Devil's Bowl Speedway, MUST file a resume showing their racing experience (if any) with the main office prior to competing. In addition, ALL drivers must have a valid NASCAR membership.
3. All persons going into pit area as non-members must sign the non-membership form and release statement.
4. All applications must be filled out in full. Discounted member pit fee rate will not be honored without a NASCAR membership license card and valid photo ID. Other sanctioning body memberships may be honored at certain events.

5. Devil's Bowl Speedway reserves the right to reject any membership. Devil's Bowl Speedway also reserves the right to decline any non-member admittance to the pits. Devil's Bowl Speedway reserves the right to refuse entry to speedway grounds at any time.

6. No person *or* company shall be allowed to sell or solicit products *or* services without permission from speedway management *in writing*.

7. No car will be allowed to compete without a proper number cleared by the Devil's Bowl Speedway office. *No duplicate numbers allowed. No more than three digits.* See PAINTING AND NUMBERING.

FEES

1. NASCAR WHELEN ALL-AMERICAN SERIES LICENSE:

- **Division I / Feature (Modified) Driver or Owner: \$200 (15-Day: \$50*)**
- **Division II-IV / Charger (Late Model, Renegade, Mini Stock) Driver or Owner: \$100 (15-Day: \$25*)**
- **Crew Member: \$100 (15-Day: \$25*)**

** 15-Day license may be purchased multiple times. Fees can be applied to full license upgrade. Must be fully licensed member to receive point funds and special awards from NASCAR.*

Note to car owners: Car number from prior year will only be reserved until February 15, all cars must be registered with Devil's Bowl Speedway Car Registration Form.

Pit & Entry Fees may vary depending on event.

Members agree to abide by all rules set forth by Devil's Bowl Speedway and/or NASCAR. No refunds of pit and/or entry fees.

GENERAL RULES

1. The track official in charge has the right to reject the entry of any car or driver.
2. The decision of the race officials on interpretation of rules pertaining to racing or race procedure shall be final.
3. The scorer's decision on position is final.
4. Anyone involved in an accident while on the racing premises and who does not report to the official in charge before leaving the premises (provided they are able to make such a report) will not be eligible for benefits prescribed under the Benefit plan.
5. The race director is empowered to permit deviation from any of the rules or specifications herein set forth if, in their opinion, the safety factor is not lowered.
6. **The owner and driver only may represent their team in any and all matters pertaining to the race.**

7. At no time shall anyone subject any Devil's Bowl Speedway official to abuse or use improper language at any time. No one shall participate in fights on race premises at any time. Violators of these rules may be fined or suspended or both. See item #2 under "VIOLATIONS, SUSPENSIONS, FINES."

8. Devil's Bowl Speedway reserves the right to subject any car to mechanical inspection at any time.

PIT PROCEDURE

1. All members shall properly sign into pit area in accordance with track policy, and no one shall be allowed in without proper registration and pit pass.

2. Each car must be checked in with the official at the designated area immediately upon arrival at the track. Either the owner *or* driver will be responsible for checking the car in. If a car arrives late *or* officials have not been properly notified of its presence, the car **will not be handicapped**. Any new car **MUST** be checked in and a number assigned before entering the pits.

3. All excess oil shall be deposited into the waste oil drum provided by the speedway. **THERE WILL BE NO DUMPING OF OIL ON THE GROUND!** This oil dump station will be located at a pre-announced spot. If the day after the race a race team's pit is found to be in violation of the above, the speedway shall charge the car owner a reasonable fee to correct the violations. This money shall be deducted from any prize money the car has won. Continual violation may mean suspension.

4. It is mandatory that all car owners and drivers be present at the pit meeting. The pit steward shall have the option of determining when or if a pit meeting will be held.

5. THERE SHALL BE NO DRINKING OF ALCOHOLIC BEVERAGES IN THE PIT AREA AT ANY TIME – BEFORE OR DURING THE RACES.

TRACK PROCEDURE

1. No car or cars shall be allowed on the track unless the official starter is on duty and he has given permission.

2. At no time will a pit crew or car owner be allowed on the track. Violators may be subject to fines and/or suspensions.

3. **NO** repairs will be made on the track, at the track gate, or the infield *at any time*. All repairs must be made in designated pit stalls.

4. If a member of the pit crew touches the car for any reason the car must start in scratch position, and any time a car must go to the pit area for repairs, the car must go to the rear of the field. Any car asked to report to pits by a race official for safety

inspection during a race will be allowed to get their position back if no work was needed on car.

5. Any driver who – in the judgment of the officials in charge – causes the race to be halted, *shall be penalized a minimum of one lap.*

6. No driver, owner or mechanic shall have any claim for damages, expenses or otherwise against the track owners or promoters or track operators, by reason of disqualifications or damage to car or driver or both. *They agree that the track is in a safe and usable condition when they take part in the racing activities, and that they enter the course on their own free will. The race course is open for inspection at any time prior to practice time.*

7. All participants are subject to Devil's Bowl Speedway/NASCAR rules and regulations when on the racing premises. The first warm-up lap shall be considered the start of an event.

8. A race may be stopped at any time at the discretion of the starter or officials if they consider it dangerous or unsafe to continue. If race is stopped under these conditions, and is past the halfway point, the race will be considered officially finished.

9. In case of an accident in the first lap we will go back to original restart minus the cars involved who will fall to the rear as they emerge from the accident. All accidents shall be cleared under the yellow flag (if possible). If the red flag is displayed after a caution flag it means a caution stop, and all cars will keep in line in the position that they are running. If caution laps are being counted and a red flag condition occurs, the race may resume under yellow and laps will continue to be counted.

10. In the event of a red flag that stops the race, cars will line up in the order that they were running at the last completed lap.

11. Restart order after a caution will be the last fully completed lap. In the event that enough laps have been completed to call the event official, the drivers shall be scored and paid on the position they would have had on the restart.

12. When the checkered flag has been given the leader or winner, the balance of the field receives the checkered flag in the same lap and the race is finished.

13. Finishing positions shall be paid off according to the distance traveled regardless of whether the car is running or not.

14. It shall be the responsibility of the safety crews to clear the speedway as quickly as possible so the race can restart. Any driver who shall interfere with this shall automatically be suspended for one week.

15. No race shall be considered official until the official declaration of the winning position is made and posted by the track officials in charge. **If no protest is filed within 10 minutes after finishing positions are posted, the finish shall be considered official.** All protests must be made in writing to the pit steward on official protest form.

16. Any driver who drives through the infield in a reckless manner may be placed one lap down or black flagged from that event at the Race Director's discretion, and may be suspended, fined or both.

17. Any driver who drives into or through the pit area while at a high rate of speed or in a reckless manner while making a pit stop shall be held at the pit gate for one lap when he returns to the speedway, or may be disqualified, and/or may be fined a monetary amount at the discretion of officials.

18. Drivers who do not fall in line on restarts may be put to the rear of the field, may be black flagged, or may be disqualified.

19. A car that loses its position during an accident may not return to its original position if a car or cars have passed him, but may pick up the position behind the last car to pass him. Race Director has the ability to waive this rule.

20. After all the cars in the pack have passed the scene of the accident, the remaining cars that have not assumed a position will go to the rear of the pack in the order they leave the accident.

RACE PROCEDURE

1. Cars must take the original green flag in any race to qualify to finish that race.

2. Any car requiring assistance to start for any reason must go to the rear and may be black flagged. Exception – if stopped by flagger.

3. Any car requiring assistance to start after being stopped by the flagger can assume its position held before being stopped unless instructed otherwise by the flagger.

4. Once a race has started driver switches are not allowed.

5. Any driver refusing to go to the rear shall be penalized a minimum of one lap, and possible disqualification from event with no money paid or points earned.

6. Any driver refusing to take the black flag may be suspended at least one week.

7. Once the car qualifies for the event any driver changes shall result in the car starting in the rear!

8. Cars who drop out of the race for any reason during a qualifying event must go to the pit area or infield, unless announced otherwise.

9. The top five cars in all divisions running at the end of the feature must report directly to the scales before going to his or her pit area. There will be no exceptions.

HANDICAP & SCORING RULES

1. To be handicapped or allowed to draw for position a **car** (not just a crew member) must be in the pits prior to the first scheduled race of the program. It is the responsibility of the driver or car owner to notify the handicapper of driver changes.

2. Handicapping is based on points earned by driver during the previous three races at that track. If the driver hasn't been at the track with a car for any of the three previous races he is assigned winner's points for the races missed.

3. The number of cars to be qualified in each heat will be posted before each race meet.

4. The number of cars to start the main event may vary, depending on the total number of cars entered in that division on that particular night.

5. It is the driver's responsibility to notify the track handicapper one half hour before the heat races if he is driving a different car than he last drove at that track. If he does not notify the handicapper any points and money won will be forfeited.

6. It is the driver's responsibility to notify the track handicapper if he is driving a car in the consolation race he did not drive in a heat. Failure to do so will disqualify him from the feature. He will start last in the consolation race. Driver will receive last place points if he/she cannot find an approved car to compete in. When substituting cars in an attempt to qualify, both car and driver must be in pit area.

7. It is the driver's responsibility to notify the track handicapper if he is driving a car in the feature that he did not qualify. Failure to do so will disqualify him from any points or money. He will start last in the feature.

8. If a driver drives a car in the feature that he did not qualify, both he and the driver who qualified the car will be assigned the points earned for handicapping purposes.

9. Only cars that are in the pits during heat races will be allowed to race in the feature, unless handicapper has been notified that the car will be late.

10. If a DRIVER misses his posted heat or goes in the wrong heat the car may be placed last in the consolation or start in the rear of his or her posted heat race.

11. Officials have the right to position a qualified car further back in the lineup if it is for the betterment of the race.

12. If a driver qualifies two (2) or more cars, he must drive the last car that he qualified in the feature race, and the first car he qualified must re-qualify.

13. No feature winners can start in the top-eight in the feature unless the number of non-feature winners will not allow it. In all divisions, the previous event's feature winner will be required to start in the LAST position in the next feature.

14. If any division has less cars entered for the night's racing event than it normally starts in the night's feature, officials have the option of not running a consolation event. If heat races are run and any car entered fails to make the starting field in the qualifying race that car will be allowed to start the feature race in last place. **To qualify you must take the original green flag.**

15. A new driver shall start from the scratch position in the heat race for three (3) weeks. **No exceptions.**

16. All cars in all divisions racing at Devil's Bowl Speedway will be required to have a working transponder for use with the MYLAPS computer scoring system. The MYLAPS website is located at www.mylaps.com. No duplicate car numbers will be allowed! Three digit numbers are allowed. Failing to notify the track handicapper of a transponder change prior to the start of the first race of the night will be cause for automatic disqualification. No points or monies will be paid. It is the driver's responsibility to have the transponder on at all times. If transponder is not on, car will not be scored! Race officials shall attempt to notify cars during warm ups if their transponder is not working.

POINTS / PAYOFF / HANDICAP

1. Points and point funds shall be established on a current basis and will be pre-announced at the beginning of each racing season as to value, etc. All NASCAR point fund money will be paid according to their rules. No point fund money will be paid to any driver who does not have a valid NASCAR license or to any driver who has not fulfilled Devil's Bowl Speedway/NASCAR requirements.

2. Any driver receiving additional (non-NASCAR) point fund money or awards must attend the annual banquet in order to receive prizes.

3. The owner may designate someone to pick up payoff by written request only. Owner will be required to show valid proof of ID in order to receive any purse/payoff money.

4. Points will be gained in heat and feature races, unless otherwise announced. At events where a semi-feature is held, points will be gained in that race as well.

2014 Point Structure:

Heat Races

1. 5 pts.
2. 4
3. 3
4. 2
5. 1

All others receive 1 point.

Semi-Features

1. 10 pts.
2. 9
3. 8
4. 7
5. 6
6. 5
7. 4
8. 3
9. 2
10. 1

All others receive 1 point.

Feature Races

1. 50 pts.	11.30	21.10
2. 48	12.28	22.10
3. 46	13.26	23.10
4. 44	14.24	24.10
5. 42	15.22	25.10
6. 40	16.20	26.10
7. 38	17.18	27.10
8. 36	18.16	28.10
9. 34	19.14	29.10
10. 32	20.12	30.10

All others receive 10 points.

1. Drivers not starting heat race will receive 0 heat points.
2. Drivers not starting semi-feature will receive 0 semi points.
3. Drivers qualified but unable to start feature may receive last-place points.
4. Drivers not qualifying for feature will receive 10 points.
5. Consolation races do not award points.
6. Tow points (minimum pts. per event) = 10 points.

2014 Handicap Procedure

1. Weekly handicap value will be sum of all **feature race points** accumulated at event (**regular event maximum = 50 points**). **Heat and semi-feature points will not be included in handicap value.**

2. Handicap will be average of three (3) most recent events.
3. **Missed event = 55 handicap points. (Max. 50 points, plus 5-point penalty)**
4. **Event disqualification = 55 handicap points. (Max. 50 points, plus 5-point penalty)**
5. Rookie/novice drivers may be required to forfeit handicap until able to display the ability to control his or her car and keep the pace with the field under race conditions. All rookie/novice drivers will be evaluated on a case-by case-basis. Any driver that cannot keep pace with the field may be assigned a starting position at the rear of the field until he or she can display enough control and speed to compete and maintain a regular handicapped position.
6. Devil's Bowl Speedway reserves the right to make changes to handicap procedure in the interest of fair competition.

PROTESTS

1. NO protests will be considered or allowed while the race is in progress.
2. A protest regarding any matters pertaining to mechanical specifications must be made within ten (10) minutes after the finish of the race. Protest must be made in writing with a \$500 cash bond.
3. A protest may be made by a driver or car owner *only*, who must be a member in good standing, participating in that event. Person filing protest may also have to tear down.
4. The officials may enact their own rules for the conduct of the hearing and prescribe the manner in which either track-mandated or protest teardowns may be executed. All decisions made by track officials or inspectors shall be final. It is further stated that no driver, owner or any person or parties shall have any legal claim for damages, expenses or otherwise against track owners or promoters or track operators, its employees, sponsors or any party or parties involved with speedway management regarding any and all decisions involving race procedures, finishes or technical inspection decisions. By entering any race meet you agree to this and waive any rights to any legal claims against the above mentioned entities. Furthermore, speedway management shall have the right to seek reimbursement of any legal fees incurred from any such claims. All decisions of the race director are final.
5. In the event that the car under protest is not legal, the money will be returned. If the car is legal, 80% of the money paid will go to the car owner and 20% will go to cover the cost of the tear down.

6. Any visual protests made *after* the start of the feature race will not be investigated. (A visual protest is one that doesn't require any type of measuring device to establish the legality of any part of a car.)

7. All protests shall be in writing and presented to the pit steward only. At no time shall anyone take a grievance to the main office. **Only protests made on the official Inspection/Protest/Claim Form will be considered valid!** These are available *only* from the pit steward at the pit tower.

8. Protests regarding official race results must be made within 10 minutes of those results being posted.

9. Devil's Bowl Speedway reserves the right to reject any and all protests.

VIOLATIONS, SUSPENSIONS, FINES

All teams or anyone entering restricted pit or technical inspection areas are subject to disciplinary action for violation of these rules. Penalties for violations include disqualification, suspension, fine and/or loss of points. The nature of the penalty is determined by the gravity of the harm to the safety and good reputation of stock car racing.

1. Anyone who assaults or threatens to do bodily harm to any official, track employee, or persons serving under his direction may be suspended, fined not less than \$500 and shall lose all points for race meet and may lose all accumulated points.

2. Anyone who participates in fights in pits, on track or race premises, will be fined a minimum of \$500, may be suspended, and may not return until the fine is paid. Anyone involved in fighting while on speedway grounds will not be covered by track and pit benefits and may have the privilege of attending sanctioned events revoked indefinitely.

3. Any car that is found with unapproved parts or in violation of rules will lose all points for the event, and at the discretion of the race director and/or technical inspector may lose all points accumulated for the season, depending on the severity of the infraction. **It is further stated that any and all unapproved parts may become property of Devil's Bowl Speedway without claim and will not be returned.** Race teams that have unapproved parts confiscated will have no legal claim against Devil's Bowl Speedway, its employees, sponsors or any party involved with Devil's Bowl Speedway events.

4. Any person, while participating in a sanctioned event or who signs into the pits on race day, may be subject to random drug and/or alcohol testing, and any person who partakes of any alcoholic beverage or illegal drugs shall immediately be ejected from the racing premises, and shall be subjected to a mandatory fine of not less than \$500 and automatic suspension. Anyone who refuses to be tested will have the privilege of attending sanctioned events revoked indefinitely.

5. Any person who fails to obtain a competitor's permit and/or sign release forms for that particular meet will be subject to a mandatory fine of not less than \$100 and/or disqualification of driver and car associated with the violation.

6. Any person who permits someone else to use his or her membership license will be subject to a fine of not less than \$100 and may be suspended indefinitely; any driver permitting another person to use his or her membership license may lose accumulated track and/or NASCAR points. Any person who attempts to use a membership license other than his or her own shall also be subject to the same. Membership license and photo ID MUST be shown to gain entry into the pits as a member. Non-member fees *will be charged* without proof of membership. NO EXCEPTIONS.

7. Any member who signs the release sheets or competitor's permit for someone other than himself or herself shall be subject to a fine of not less than \$100.

8. Any member who causes the racing program to be halted for any reason such as personal grievances may be subject to a fine of not less than \$200 and/or loss of all accumulated points.

9. Any member, car owner, or driver in violation of any spec engine rules or found to be tampering with gasoline will lose all accumulated points to date. Driver and car owner will be suspended for **one calendar year** from the date of infraction. The driver is as responsible as the car owner, and it shall be the responsibility of both the car owner and driver to know what is approved and what is unapproved, and which parts are used in the race car that he or she owns and/or may be driving.

10. All fines shall be paid before offending person will be allowed into the pit area or premises.

11. **Any member who attempts to bring any grievance to the main control tower may be fined not less than \$500, the member's race team may lose all accumulated points for the year, and the member may be suspended.** The race team involved may also lose all points for that event.

12. By signing release sheets and upon entering speedway grounds and agreeing to abide by the rules of the organization, it is agreed that **Devil's Bowl Speedway has the right to remove any engine** and have Devil's Bowl Speedway-approved engine shops only perform random technical inspections.

Devil's Bowl Speedway Approved Engine Builders:

- RPM Racing Engines, 331 Carpenter Hill Road, Georgia, VT, phone 802-524-7406, www.rpmenginesvt.com
- Hunt's Machine, 102 Weaver Street, Schenectady, NY, phone 518-372-7273, www.huntsmachine.com
- **DMO Motors, 83 Bridge Street, Plattsburgh, NY, 518-563-2749**

The only goal is for parity for all race teams that compete weekly at Devil's Bowl Speedway. Devil's Bowl Speedway receives NO monies from RPM Racing Engines or Hunt's Machine, only technical support for speedway management. Every engine will be recorded and records kept by Devil's Bowl Speedway and the engine shop.

Engines will be removed from time to time and shipped to RPM Racing Engines for inspection; the engine will be inspected and dynamometer tested. Any unsealed engines will be removed and inspected sooner rather than later. If the engine is approved the race team will have the option of sealing the engine for \$425. If the engine is approved and the race team does not want the engine sealed, then tech costs the first time will be covered by Devil's Bowl Speedway. The unsealed engine will still be considered an "open" engine. The cost for tech on an "open" engine that has to be removed and inspected once from the car and shipped to RPM Racing Engines will cost the race team \$425 in delivery and labor costs to inspect the engine. Each subsequent time after the first time an engine is removed for inspection, the cost of \$425 for shipping and shop labor will be borne by the race team, whether the engine is determined to be approved or not.

13. If any race team refuses technical inspections on its car, the car itself, the car owner, and the driver may be suspended for **one calendar year**. Crew members of said car may also be subject to suspension. Race team may forfeit all accumulated points to date.

OFFICIAL FLAG RULES

Any driver who does not obey the flag rules will be subject to disqualification. Where light signals are used, a definite understanding concerning these signals in relation to the flags shall be made before the race.

GREEN FLAG – Start of race.

BLUE FLAG/YELLOW STRIPE – For passing, and will be displayed only when you are being lapped.

YELLOW FLAG – Caution, go slow, single file, hold position, *no passing!*

RED FLAG – Danger, all cars must come to a safe and controlled stop. Driver may proceed only after race official permits and it is safe to proceed.

BLACK FLAG – Pull off track for consultation.

WHITE FLAG – One lap to go.

CHECKERED FLAG – End of race.

PAINTING AND NUMBERING

All cars must be neatly painted and lettered. Numbers must be approved by Devil's Bowl Speedway when owner registers them *each year*. Prior year's numbers have preference if reserved by February 15th. After that date they are reserved on a first-come, first-served basis. Car numbers that are reserved require participation. Numbers that are reserved and not used will be given to someone else upon request. We may notify you if there is a request for a reserved number that has not been used. No more than three-digit letter/number combinations allowed. No more than one letter in

combination with one or two numbers allowed. No fractions allowed. Numbers must be **at least 18" tall and no less than 3" thick**. Numbers must be as large as possible to facilitate scoring. Numbers must be in *contrast to car body color*. Any silver, gold or chrome numbers will not be allowed, nor will the use of "color chrome" on numbers or lettering be allowed. If the body is light, the number must be dark, and if the body is dark, the number must be light. Numbers shall be on each side of the car *and* on the roof. The number on the roof should face the scoring tower, with the bottom above the passenger door area.

All letters must be NO SMALLER than one-third the size of the car number, and letters must be the same color as numbers. If there is a three digit number used, then the size and the color of all three digits must be the same.

Devil's Bowl Speedway reserves the right to approve or disapprove any car number request.

The use of clear Lexan door protectors is strongly recommended for Late Models, Renegades and Mini Stocks.

Scorers have final say on how numbers appear on car. Car numbers are part of technical inspections. The main determining factor in allowing a number to remain as is, will be the ability to read the number from the main control tower. All monies, points or awards may be withheld until car numbers are deemed readable by race director. Owner or driver will have no claim against race management over this matter.

SCORING TRANSPONDERS

Transponders are required on the cars at all times. Any car not registering a transponder signal during practice will be black-flagged to be made aware of their scoring transponder failure and is required to remedy it before proceeding further in the event. All teams must be equipped with transponders fit to detect MYLAPS Timing & Scoring system. Model Tran X 260 recommended. Transponders will be for rent on a night-by-night basis at the speedway at \$20/each with a \$400 crash clause. Devil's Bowl Speedway holds the right to withhold any and all winnings until rented unit is returned or (in an event of a damaged unit) the crash clause is paid. If transponder is not returned, whether damaged or not, the driver will be responsible for full retail cost of the unit, at \$400. Failure to mount transponder in specified location may result in disqualification from race meet. Race team will not receive any points or prize monies for event.

SAFETY RULES

The following safety rules shall be in effect for all divisions of Devil's Bowl Speedway competition – any variation from said rules in a particular division shall be noted in that division's own rules section. ALL CARS ARE SUBJECT TO SAFETY INSPECTION BEFORE THEY ARE ALLOWED IN COMPETITION.

Roll Bars

1. Steel roll bars are compulsory, and must be approved by Devil's Bowl Speedway. Aluminum and other soft metals are not permitted. Front and rear roll bars must be connected at the top (cage type) and bottom on both sides at seat height. Side roll bars are compulsory and must extend inside into the door panels, (minimum of three on left

and right side) with additional support on the back of the roll bars. Side door bars should be convex in shape, with some arch. An additional bar must be installed across the bottom of the dashboard, extending from the left roll bar leg to the right roll bar leg. All full-fendered cars will be required to install an additional "windshield safety bar" to the roll cage. Dimensions of safety bar shall follow recommended sizes below.

2. All pipes and bars must be professionally welded all the way around at every joint, and must be 1 $\frac{3}{4}$ " o.d. recommended minimum and walls not less than .095 steel recommended minimum **or** 1 $\frac{1}{2}$ " o.d. recommended minimum and walls not less than .120 steel recommended minimum. No pipe fittings allowed. It is recommended that all welds have gussets. Pipe must be seamless, drawn over mandrel.

3. Roll bars in the driver's area must be padded with polystyrene or similar fireproof material.

Safety Belts

1. No aircraft surplus belts allowed.

2. A quick release belt no less than 3" wide is compulsory. Seat belts must be within three (3) years old.

3. Shoulder harness and additional V-type seat belt compulsory.

4. A sub belt must also be used. It must be bolted to the floor in such a manner that it can be hooked into the seat and shoulder belts.

5. Both ends must be fastened to the roll bar cage of the car with aircraft quality bolts, not less than $\frac{3}{8}$ " in diameter.

6. A steel plate may be welded to the roll bar cage on the right side of the driver so the belt can be brought down in such a manner that it will keep the driver from sliding from side to side under the belt.

7. The belts must come from behind the driver.

Firesuits/Driver Safety Gear

It is recommended that all drivers wear a SFI certified firesuit with at least a 32A-1 rating, but a 32A-5 suit is recommended. Fire retardant underwear, arm restraints, gloves, racing shoes, and brace or padded strap "horse type" collar neck support highly recommended! Use of HANS or Hutchins device strongly recommended.

Helmets

All helmets must have full head coverage. Devil's Bowl Speedway recommends but does not require all helmets to carry a **Snell 2005** or newer certification.

Seats & Headrest

One piece high back aluminum racing seat only. Seat must be welded and bolted to the frame with minimum $\frac{3}{8}$ " bolts and washer with lock nuts. Headrest must be of adequate size so as not to allow the driver's head to pass on either side.

Fire Extinguishers

Fire extinguishers recommended in all cars. Each team **MUST** have fully-charged fire extinguisher at the rear of their trailer at each event. **(THIS WILL BE CHECKED!)**

Switches

1. Switches must be within reach of the driver after he is strapped into the car.
2. Switches are mandatory for fuel and battery and must be clearly labeled on and off.

Fuel Tank

1. Fuel tanks (22 gallon max.) must be secured with steel straps, not less than two lengthwise and two crossways. Fuel cells must be properly bolted into place. *Fuel cells are mandatory in Modified, Late Model, and Renegade divisions, and a fuel cell is recommended for Mini Stocks.* Only approved safety ball shut off assembly allowed.
2. Steel floors and firewalls are compulsory and must separate the driver from the engine and gas tank. Firewalls must be not less than 20 gauge steel, securely welded and sealed on the top, bottom and sides. Where the stock floor and firewalls are used all the holes must be covered with steel and welded or riveted.
3. All bodies must be installed on the frame in a safe approved manner.
4. No external filler connections. Filler tube neck must remain totally inside the trunk area. No access holes for filler neck are allowed. The trunk cover must have to be opened to add fuel.

Gas Lines/Fuel Pumps

Gas lines should run under bottom of car or properly encased if run through the body. Neoprene tubing recommended. **NO ELECTRIC FUEL PUMPS ALLOWED.** No pressure systems allowed. Bombers may use OEM factory stock-type fuel pumps.

Cooling Systems

Positively no antifreeze / engine coolant or other glycol based liquids allowed. Water and only approved water wetters allowed. Any driver found using such fluids will be subject to a \$250 fine.

Brakes

Only hydraulic four-wheel brakes allowed, and must be in excellent working condition at all times.

Miscellaneous Safety

1. A steel scattershield, not less than $\frac{3}{8}$ " thick must be installed over and around flywheel and clutch. Special production clutch housings are permitted in lieu of separate shields.
2. NO DOG CLUTCHES ALLOWED. The car must be able to shift into forward and reverse gear with motor running.
3. All Modified cars must have a protective shield over the drive line to protect the driver in the event the drive shaft comes unhooked. The protective shield must be at least 180° and cover the drive shaft. Steel of no less than $\frac{1}{8}$ " thickness must be used and must extend from transmission to rear of the driver seat (top to floor).
4. **All driveshafts must be painted WHITE in ALL divisions.** All divisions must have a loop attached to bottom of car to hold up driveshaft in the event it comes loose from transmission.
5. All bolt-on weights must be fastened with no less than $\frac{3}{8}$ " Grade 8 bolts. Inspectors may require additional fastening of weights if deemed necessary. **All added weight MUST be painted white and labeled with car number and division.**

Starters/Batteries

Required in all divisions and must be in working order at all times.

Tow Hooks/Chains

Tow hooks are required for front and back of cars in all divisions. No less than 5/16" chain required.

Window Screen / Lexan Windshields

All vehicles must have a full window screen. This screen must have a maximum individual hole diameter of no more than 2" x 1" – no chicken wire or aluminum mesh. Use 1/16" thick steel screen.

~ **OR** ~

All vehicles must have a full windshield of Lexan type material. Must be clear and supported by one upright brace in center, with minimum thickness of 1/8". B-pillar window openings may be covered with clear Lexan only!

ALL RULES NOT COVERED HEREIN SHALL BE AT THE DISCRETION OF THE SAFETY INSPECTOR AND IF HE FEELS HE SHOULD PUT FORTH RULES ON SAFETY HE MAY DO SO AT ANY TIME.

RENEGADE SPECIFICATIONS

Renegades are meant to provide an enjoyable class of auto racing on a recreational level – not a business.

These rules were created to protect the integrity of traditional “stock car racing” and make possible equal competition among the many different stock car parts available to race car builders, and to encourage builders to use their imagination and skill and not just their money in their efforts to build a winning race car.

Because of the many types of automobiles that can be built under these rules, it is impossible for these rules to provide for every situation that might occur. Accordingly, the chief steward or race director is given discretion, following the intent of the above goals, to rule on any matters not covered specifically in these rules. Devil’s Bowl Speedway reserves the right to make changes in these rules during the course of the season should changes become necessary to ensure greater safety or more equal competition.

A General Description of the Renegade Class

Renegade class must be factory stock cars only. If the part or parts in question are not covered in the rule book, and are not factory stock for the make, year and model of your car, then they are not legal! The Renegade class is open to any closed passenger car, but no convertibles, station wagons, trucks or military vehicles are allowed. *A word of warning to Renegade car builders:* these rules are intended to keep the cost of purchasing and preparing a competitive car as low as possible. Money spent on a Renegade car should be used to make the car safer, not faster.

Renegade racing is intended to provide a low cost and fun learning experience for the beginning driver. There are many opportunities to spend more money and time building a racecar than are required to build a Renegade car. If you want to build a FAST race car, DO NOT build a Renegade car. Efforts to “bend” or find and take advantage of a loophole in these rules will not be tolerated. If your car is not inside these rules, both in terms of the specific rules that follow or above, *your car will not race!*

NOTE TO ALL TEAMS: All cars from other race tracks that fall under the general guidelines of the Renegade division are welcome. However, in the interest of fairness and parity in the Renegade division, all cars and engines will be subject to penalties including but not limited to added weight and/or restrictor plate usage. All situations will be reviewed on a case-by-case basis. We appreciate your cooperation on this issue and your effort to help create better competition. Please call (802) 265-3112 with any questions.

Crate engine seals from Island Racing (South Hero, VT) will be allowed, but are subject to inspection. The preferred crate engine builders for Devil’s Bowl Speedway are RPM Racing Engines (Georgia, VT), Hunt’s Machine (Schenectady, NY), and DMO Motors (Plattsburgh, NY).

Engines constructed by other builders, machine shops, or race teams will be evaluated on an individual basis.

Please understand that the Renegade division is currently in a rebuilding phase and is going to be considered a “work-in-progress”. Again, all cars that fit the general

scope of the rulebook are welcome to race, but be advised that in the interest of fairness some changes may be made to certain individual cars based on performance, particularly with cars that dominate competition on a regular basis.

Engine Registration

All Renegade teams will be required to disclose to tech officials the engine type. Tech staff will then log the engine type and serial numbers. For all World Product heads the serial numbers will be cross-referenced and all numbers will be logged into tech sheets.

It is the responsibility of the car owner and driver to report any engine changes BEFORE car enters into competition.

Failure to report any engine changes to Devil's Bowl Speedway will result in the following penalties. Failure to report an engine or engine part change before car enters into competition for night, or any "team" found tampering with "spec engine" will be disqualified from event and fined \$1,000 before they are allowed to return. Competitor will lose all points accumulated to date, and will be suspended for **one calendar year**. This will be a minimum penalty for this violation. Upon second offense team will be suspended for **one calendar year** and fined \$2,000. Teams that are multi-time violators of tech rules may be suspended indefinitely. Any team found tampering with Devil's Bowl Speedway-approved engine seals **WILL** be suspended for a minimum of **one calendar year** and will be fined a minimum of \$2,000.

Engines and Carburetor

Any member, car owner or driver in violation of any spec engine rules or found to be tampering with gasoline will result in loss of all accumulated points to date. Driver and car owner will be suspended for the remainder of the racing season. The driver is as responsible as the car owner, and it shall be the responsibility of both the car owner and driver to know what is legal and what is illegal, and what parts are used in the race car that he or she owns and/or may be driving.

1. Maximum cubic inch limit

Chevrolet - 350 c.i. / Chrysler - 360 c.i. / Ford - 351 c.i. "Windsor Only"

Example: If your car is a Chevrolet and came stock with a 305 c.i. you may interchange with a 350 c.i.

2. All engines are allowed .040 clean up for wear.

3. Any stock unaltered steel production cylinder head is allowed. Maximum valve size .194". All heads must be passenger car type only. No marine, truck, double humped or high performance cylinder heads allowed.

OPTION #1 602 GM Crate Engine Package:

- Requires use of GM Crate Racing Engine Part #88958602.
- Devil's Bowl Speedway has approved the use of the Holley two barrel model 4412 for 602 crate engine users.

• Devil's Bowl Speedway Renegade 602 crate engine exhaust system: Maximum exhaust pipe diameter is 2 $\frac{1}{2}$ ". The complete exhaust system must remain under car and exit to the rear behind driver. Stock cast iron, unaltered exhaust manifolds are permitted. Optional factory steel street headers are allowed. Primary pipes must maintain a 1 $\frac{5}{8}$ " diameter from flange to collector. Crossover headers (not 180° headers) are allowed with primary pipes that maintain a 1- $\frac{5}{8}$ " diameter from flange to collector. Maximum header flange or adapter flange thickness is $\frac{3}{8}$ ". **No coated ceramic, merge collectors, 180° or exotic type tri-Y high dollar headers allowed! Budget type headers only.**

GM CRATE ENGINE 602 RENEGADE

The following are approved engine shops for 2014:

- RPM Racing Engines, 331 Carpenter Hill Road, Georgia, VT 05748. Phone 802-524-7406.
- Hunt's Machine, 102 Weaver Street, Schenectady, NY 12305. Phone 518-372-7273.
- **DMO Motors, 83 Bridge Street, Plattsburgh, NY 12901. Phone 518-563-2749.**

Only engines that have been logged into service and inspected by the above engine shops will be eligible for this engine option.

OPTION #2 Devil's Bowl Speedway-approved Sealed Hunt's Machine #HE-602-350-350:

- Hunt's Machine, 102 Weaver Street, Schenectady NY 12305. Phone 518-372-7273.

Only engines that have been logged into service and inspected by the above engine shop will be eligible for this engine option.

OPTION #3 Home-Built Engine:

No relieving or unshrouding of valves in the combustion chamber. Valve head sizes are optional providing they maintain stock OEM positioning in valve guides (distance apart and angles). Valve guide liners are allowed. Any carbon fiber engine parts are illegal. Any amount of valve seats per cylinder head may be installed for the purpose of repairing a head. Valve stem maximum and minimum diameter, plus or minus .005" must be as follows: Chevy $\frac{11}{32}$ ", Chrysler $\frac{3}{8}$ ", Ford $\frac{11}{32}$ ". No hand grinding, sanding, blending or de-burring where a cutter or stone leaves off. The amount of metal you may remove in bowl areas on both intake and exhaust will be checked as follows: On exhaust side the exhaust manifold will be removed and the inspector will place a .531" diameter ball bearing welded to a $\frac{1}{4}$ " flexible shaft. With valve fully opened, the ball will be placed against the valve stem and moved in a full circle (360°) around the valve stem. If ball drops down through the valve seat in any position around the full

circle of the valve stem, it will be declared illegal! On the intake side the carburetor will have to be removed and in some cases the intake manifold. The same procedure will be performed as described for the exhaust side except the ball size will be .787". **Note:** This method of checking the heads will be regardless of engine being hot or cold. No extra time will be given for the engine to cool off.

Intake Manifold Option #3

Devil's Bowl Speedway-approved aluminum or Brodix Part #HV1011-1 (has DIRTcar cast mark)

~ **OR** ~

Brodix Part #HV1011 are the only approved intakes.

Intake must remain OEM factory stock. No alterations of any kind allowed.

ALL ENGINE OPTION PACKAGES:

Exhaust Manifolds / Headers

Optional factory steel headers are allowed. May use cast iron exhaust manifolds. No center dump type manifolds. Passenger car type only! Exhaust must extend beyond the back of the drivers seat. Mufflers are recommended. Must remain dual exhaust, no crossover or "Y" pipes allowed. No alterations – stock OEM only! No grinding, polishing, porting or acid porting.

All engine packages may use the Devil's Bowl Speedway Renegade 602 crate engine exhaust system: Optional factory steel headers are allowed. Mufflers and exhaust system is mandatory. Only stock or "California Turbo" mufflers will be allowed. The use of round glass pack type mufflers is allowed. Mufflers may not be altered or modified from original design in any way. Maximum exhaust pipe diameter is 2 1/2". The complete exhaust system must remain under car and exit to the rear behind driver. Stock cast iron, unaltered exhaust manifolds are permitted. Optional factory steel street headers are allowed. Primary pipes must maintain a 1 5/8" diameter from flange to collector. Crossover headers (not 180° headers) are allowed with primary pipes that maintain a 1 5/8" diameter from flange to collector. Maximum header flange or adapter flange thickness is 3/8". **No coated ceramic, merge collectors, 180° or exotic type tri-Y high dollar headers allowed! Budget type headers only.** All cars are required to meet 95 noise decibel reading. All decibel readings will be taken at speedway property line. Any cars that do not meet this requirement will be disqualified.

Camshaft

Any hydraulic camshaft. No solid lifters or roller cams. No roller tip rocker arms. No roller lifters. No stud girdles.

Crankshaft

Stock OEM only. No alterations except for balancing.

Ignition

Stock OEM ignition system only. No ignition control boxes.

Fuel

Regular Unleaded fuel ~OR~ 110 Octane Sunoco race fuel allowed. NO Crate Extreme allowed. NO additives allowed. Fuel WILL be tested.

Radiators

Any stock passenger type radiators allowed. Aluminum radiators are allowed but must be stock passenger car type. NO RACING TYPE RADIATORS! If using a windshield screen, any overflow tubes must be directed to the ground between frame rails, if using a windshield, any radiator allowed with catch tank overflow must blow on right lower quarter of windshield or wind screen. Electric fans are allowed.

Flywheels

No modular or aluminum flywheels.

Water Pumps

No aluminum water pumps on GM cars.

Pulleys

Aftermarket or aluminum pulleys are allowed.

Starter

Starter must bolt in stock location.

Harmonic Balancer

No fluid filled or aluminum damping harmonic balancers allowed.

Carburetors

Devil's Bowl Speedway has approved the use of the Holley two barrel model 4412 or stock OEM in all Renegade engine options.

Holley 2-barrel model 4412 venturi size $1 \frac{3}{8}$ " and a maximum throttle bore of $1 \frac{11}{16}$ ". No polishing anywhere air flows. Choke horn cannot be removed. Venturi area must not be altered in any way. Stock butterflies only. Idle holes may be drilled out to .125. Throttle shaft must remain stock and may not be thinned in any way. A maximum $1 \frac{1}{8}$ " spacer height including gaskets between carburetor and intake. Must have two return springs on throttle!

Rochester carbs: Holley jets can be used in Rochester carbs. May remove choke plates, jets may also be changed. No other alterations allowed – stock OEM only! Use of open-faced aftermarket air filter with solid top "hub-cap shape" is permitted.

Devil's Bowl Speedway will enforce a \$600 maximum (list price) rule in the Renegade division. No Demon carburetors allowed.

Pistons

Flat top pistons only.

Rods

Stock OEM only. No modifications except balancing. If found illegal at any time, offender will lose all accumulated points for the year, be disqualified from race with no pay, and will receive no points for remainder of season. Offender will start in back of every race for balance of racing season. Second offense will result in a 30 day suspension (which includes car and driver not being allowed in pit area). Third offense the car and driver will be suspended for the balance of the racing season (possibly longer) and must re-apply for reinstatement.

Car and Body Specifications

1. 1960 to present American made passenger car with factory steel top. Sunroofs and T-tops must be reinforced and enclosed.
2. 110" wheel base minimum for unibody cars, 108" for full frame cars. **NO TOLERANCE.**
3. No convertibles, front-wheel drive, 4-wheel drive or rear engines. No Camaros or Firebirds.
4. All bodies must be steel or stock. No altering or channeling of body allowed. Aftermarket nosepieces and tail pieces are allowed. No cutting out bodies to lighten car. Car must stay close to original weight.
5. Full floor boards must remain intact and visible with a metal firewall separating driver from fuel tank and trunk area.
6. Firewall between engine and driver must be in stock position. All holes must be covered. Replacement dashboard must be in factory stock location or as close to factory stock as possible.
7. All glass, plastic, upholstery, rear seat, lights, and chrome removed. Mirrors are not permitted.
8. All doors must be secured shut. (Welded, chained, bolted, etc.)
9. The fenders may be reasonably trimmed for tire clearance only.
10. All inner tin from hood, trunk lid and roof deck, and front and rear fenders may be removed.

11. Hoods may be hinged or may be pinned. All hoods must have handle on front of hood for fire/safety crew to easily grasp. Hoods may be cut open to allow for clearance of air cleaner only and opening must face driver. No ram air induction! Aftermarket hood scoops are available and highly recommended. Tech department has final say on approval of any and all hood scoops.
12. Door skirts are allowed. A 4" minimum clearance must be maintained. This rule is absolute.
13. Rear spoilers are allowed. Must be made of .090" minimum thickness aluminum with maximum width of 60" wide and 3" high. No side enclosure, no lips or bends in upper portion of spoiler. Spoiler must be flush to vertical surfaces of deck lid, non-adjustable.
14. All cars must have a racing seat that must be fastened to roll cage, NOT bolted to the floorboard. (See construction guidelines at end of this rule book.) Seat must be bolted in a minimum of six (6) spots to the roll cage using no less than $\frac{3}{8}$ " Grade 5 bolts.
15. Batteries must be mounted under hood and totally encased to prevent terminals from shorting out. Batteries must be mounted in either stock location or in firewall under hood where heater core was located.
16. Fuel cell **MANDATORY**, 22-gallon maximum. Fuel cell **MUST** be mounted on top of frame rails.
17. No plastic fuel filters.
18. Driveshaft loop is required and must be constructed of at least $\frac{1}{4}$ " x 2" steel and should be mounted no more than 6" back from front of driveshaft. Driveshaft must be painted white.
19. Brakes on all four wheels must work at all times. Brakes will be checked. The use of disc brakes on the rear wheels is allowed. All brake parts must be OEM factory stock style. No racing style brake parts allowed.
20. No aftermarket brake pedal assemblies allowed. All pedals must remain stock length, no alterations to length!
21. S-10 or Toyota slave cylinder setup or one of the same allowed. NO aftermarkets.
22. Frames may be "X" braced. Unibodies must be tied – rear frame to front frame.
23. All sharp edges, torn fenders and body panels must be repaired prior to next race.
24. Conventional and electric fans allowed.

25. On board fire extinguishers are recommended in all divisions. Each team **MUST** have a fully-charged fire extinguisher at the rear of their trailer at each event. **(THIS WILL BE CHECKED!)**

Roll Cage

See Construction Guidelines and Safety Rules elsewhere in this book. Back of cage must be no closer than 29" from center of rear axle to back part of the upright on back part of the cage.

1. Must have tow hook front and rear. Minimum $\frac{5}{16}$ " chain.
2. A single front hoop within confines of body and no wider than stock frame rails may be attached to the main roll cage. It is to be parallel to the frame and have a maximum of four (4) uprights.
3. Minimum roll cage clearance 3" from driver's head.
4. No internal reinforcement of bumpers allowed.
5. Absolutely no square tubing or galvanized pipe allowed.
6. Roll cage must be securely welded to frame. Roll cages will be inspected.
7. Fuel tank protection bar is mandatory, mounted frame rail to frame rail, no higher than the fuel cell and inside the trunk area. Bottom of fuel cell must be no lower than bottom frame rail.
8. May have two bars for protection in front of radiators behind bumper, within confines of body and no wider than stock frame horns.

Suspension

1. Must be original type suspension, some reinforcing (double nuts, washers, etc.) is allowed. Up to a 1- $\frac{1}{4}$ " front roll bar is allowed in stock location. Use of threaded rod to connect roll bar to A-arms is permitted.
2. All springs must be stock appearing and mounted in stock factory position. Springs may be chopped. Aftermarket front and rear springs allowed. Front spring rates up to 1,000 lbs. allowed. Rear spring rates up to 225 allowed. Minimum front height of car 11", minimum rear height of car 12". Minimum frame height of 6". No modifying of the suspension will be allowed unless noted.
3. Any aftermarket tubular upper A-arms are approved for use. Must be one piece steel non-adjustable. Cross shaft must be steel only. Stock type ball joint only.

4. **No rear sway bars.**

5. No spacers, lumber, or chains allowed.

6. Shocks must be stock factory type. Pro, Bilstein & AFCO stock replacement shocks allowed. Must be mounted in stock mounting position. Any other brand of replacement shock **MUST** be approved by the track. A \$70 per shock claiming rule is in effect. All shock claims will be made in writing. Shock claiming procedure will be the same as a mechanical protest. This is outlined on pages 10-11 of your official rule book. Devil's Bowl Speedway management will have the right to claim shocks. Devil's Bowl Speedway also reserves the right to have claimed shocks removed at any time during a race meet if management feels the spirit of the rules is being violated. Please note that normal removal of all claimed parts will be after the feature event.

7. Refusal of claim ... please refer to pages 11-13 of the official rule book and see "Violations, Suspensions, Fines."

Rear End / Oil Pan / Bell Housing

1. No truck rear ends allowed. Nine inch Ford rear end allowed, but must be mounted like stock rear end for that make and model. (Five bolt pattern only.) Any and all trailing arms must be one piece non-adjustable steel. The mounting nuts on bolts **MUST** be welded on. This is absolute! No welded bolts = **NO RACING!**

2. GM limited slip, welded rears, spools allowed. No Detroit lockers. Maximum gear ratio allowed is 3.73.

Transmissions / Clutches

1. Stock three speed OEM transmission **ONLY**, automatic or manual transmission allowed. No powerglides allowed. Stock torque converters only. No two or four speed or special racing automatics. Turbo 350s and C4s are allowed. No turbo 400s or 727s allowed.

2. **NO** aluminum flywheels or pressure plates. **NO** 10,000 rpm clutches allowed.

3. Stock OEM type single clutch and pressure plate only, with a minimum diameter of 10.5". All gears must be in working order. Minimum weight for clutch, flywheel and pressure plate is 32 lbs.

4. Steel scatterproof bell housings required with a minimum 1³/₄" (2" maximum) access hole for inspection at 10:00 o'clock position on bell housing.

5. No aluminum/magnesium parts will be allowed in the clutch and driveline, steel only.

Tires & Wheels

1. Official American Race track tire will be mandatory.

2. Racing wheels only. Must be 15" x 7" ONLY and must weigh minimum 22 lbs. Wheels allowed with a 3-1/2" maximum offset only, and all four wheels must be same offset.

3. 1" lug nut mandatory on all studs. No exceptions.

4. Safety hubs **REQUIRED ON RIGHT FRONT WHEEL (Heavy duty Impala style)**. All right front hubs must be solid steel only.

5. Chemical treating of tires will not be allowed. No shaving of any tires allowed in the Renegade division. A durometer rule will be in effect regarding minimum tire hardness. Durometer numbers will be determined and announced to competitors prior to first event.

6. Tire clean-up with scraper blades allowed. No form of any liquid allowed to clean tires.

7. Questionable tires, or tires not meeting above criteria as determined by officials, may be confiscated by officials and could result in disqualification and/or other penalties.

Windows

All vehicles must have a full Lexan windshield. Must be clear and supported by one upright brace in center, with minimum thickness of 1/8". B-pillar window openings may be covered with clear Lexan only!

Weight* with driver

*Management reserves the right to change weight rules at any time in the interest of competition and parity.

1. Left side: MAXIMUM 53% ABSOLUTE WITH DRIVER

Minimum weight 3,200 lbs. for cars with cage setback of 31"

Minimum weight 3,250 lbs. for cars with cage setback of 29"

Minimum weight 3,300 lbs. for cars with cage setback of less than 29" (subject to change)

2. Added Weight: Lead bars must be 5 lbs. minimum and bolted securely to frame rails and may not be concealed. All weight (bolt-on) must be located ahead of centerline of rear axle and above or on inside of factory frame rails. No weight may be hung beyond the width of the original factory frame rails, or below frame. Must be painted white with the car number on it and cannot be mounted inside the car.

3. All non-Devil's Bowl Speedway sealed engines must add 50 lbs. weight.

4-Point Roll Cage

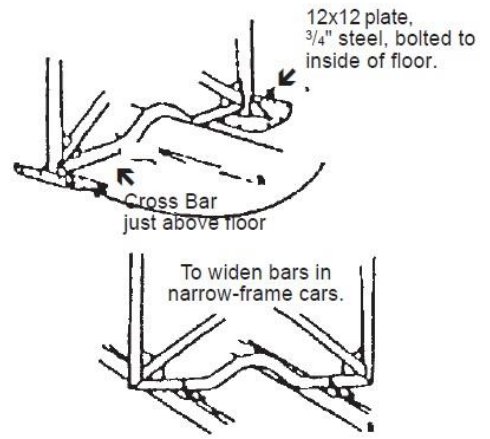
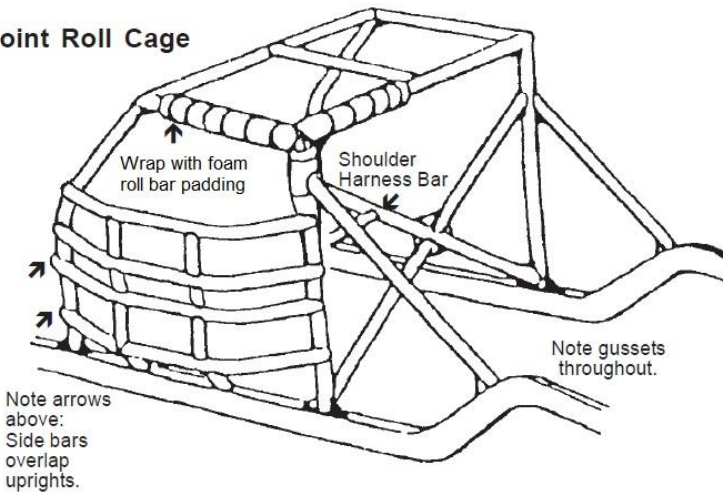

Recommended Seat Belt Installation

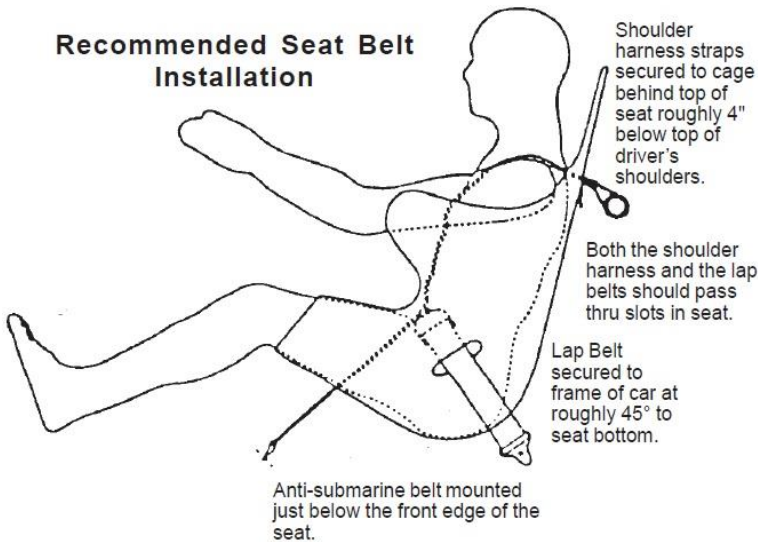

Steel Wheel Reinforcement Renegade/Mini Stock

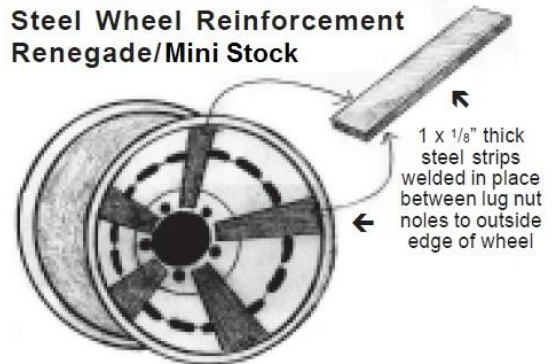

Tank Installation #1 Renegade/Mini Stock

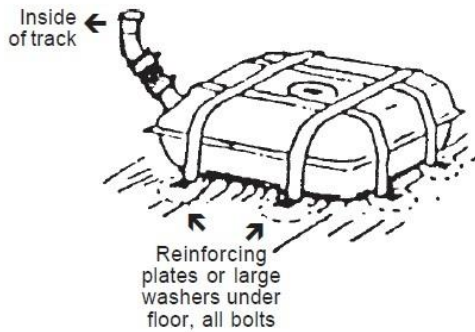

Tank Installation #2 Renegade/Mini Stock

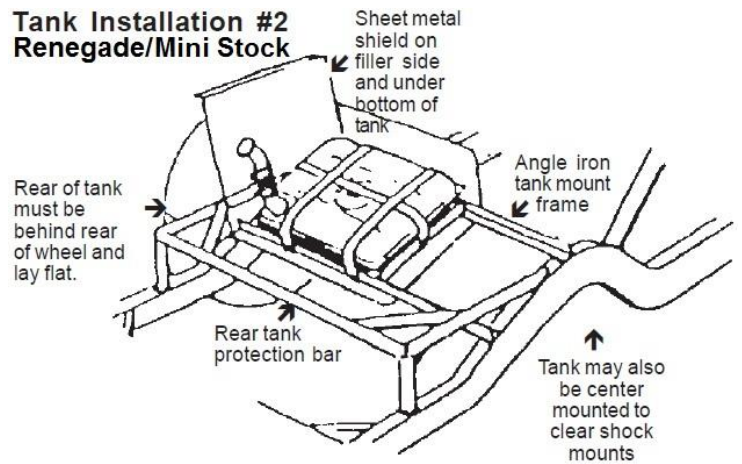

Fuel Line Protection

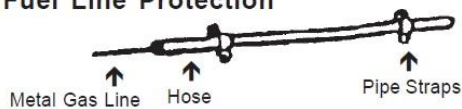



2014 COMPETITION NOTICE

DATE: April 3, 2014
DIVISION: Renegade
RE: Limited Late Model/Tiger Sportsman Cars
SUBJ.: 2014 Rules

The following is a guideline for all competitors in the NASCAR Whelen All-American Series (NWAAS) Renegade division at Devil's Bowl Speedway and Airborne Park Speedway in 2014. These rule addendums are specifically for teams wishing to compete with cars formerly run in the "Limited Late Model" division at Airborne Park Speedway or currently run in the "Tiger Sportsman" division at Thunder Road International Speedbowl, White Mountain Motorsports Park, or elsewhere.

Please understand that the 2014 season is a "transition year" as several changes in the region take place. While there have been successful tests in both a private setting and during race conditions, the blending of the Limited Late Model-type and Tiger Sportsman-type cars with the traditional Renegade division continues to be an ongoing process. Technical inspectors and race directors are making every effort to provide a level playing field for ALL competitors and to create parity within the different styles of racecars. As this process evolves, please note that these rule addendums are subject to change at any time, and **MAY NOT BE SPECIFIC TO EVERY CAR.**

As a baseline, former Limited Late Model cars will use the existing Airborne Park Speedway rulebook, while Tiger Sportsman cars will use the existing ACT/Thunder Road rulebook (no mixing of rulebooks). However, the following addendums will supersede existing rules:

Springs

1. The left-front and right-front springs shall be a 1,000-lb. maximum rate.
2. The left-rear spring shall be a 225-lb. maximum rate.
3. The right-rear spring shall be a 300-lb. MANDATORY rate – no more, no less.

4. No spring rubbers or spring bumpers allowed.

Frame Height/Jacking Bolts

1. A minimum frame ride height of 6", and a maximum frame ride height of 7", must be maintained at all points on the chassis.
2. Jacking bolts must have NO adjustability. All jacking bolts will be marked prior to competition.

Sway Bar

1. A one-inch (1") maximum sway bar must be used.

Weights

1. Left side weight percentage will be 53% maximum with driver.
2. Cross weight will be 52% maximum with driver.
3. Total weight will be 3,200 lbs. minimum with driver.

Restrictor Plate

1. At Devil's Bowl Speedway, LLM and Tiger Sportsman cars must use RPM Racing Engines restrictor plate part #1375.
2. At Airborne Park Speedway, LLM and Tiger Sportsman cars must use restrictor plate to be determined after initial testing.

Rear End Gears

1. LLM and Tiger Sportsman cars must use a 5:14 maximum rear end gear.

Tread Width/Tires/Wheels

1. Maximum tread width will be 60.5".
2. All cars must run 15" x 7" wheels and official American Racer track tire.
3. NO TIRE TREATMENT OR ALTERATION ALLOWED WHATSOEVER.

ALL RULES SUBJECT TO CHANGE WITH OR WITHOUT NOTICE. FOR ALL QUESTIONS, CONTACT DEVIL'S BOWL SPEEDWAY.



Phone: (802) 265-3112

Email: devilsbowlspeedway@gmail.com

Mail: 261 Randbury Rd., Rutland, VT 05701