



# 2015

## OFFICIAL RULES & REGULATIONS

# RENEGADE DIVISION

**NOTE: THIS IS A NEW RULEBOOK IN 2015 – PLEASE READ VERY CAREFULLY TO NOTE CHANGES FROM PRIOR YEARS!**

**REVISED 05-17-15**

All cars **MUST** be equipped with a working *RACEceiver*-type one-way scanner unit and a working *MYLAPS/AMB* timing transponder.

*RACEceiver* website: [www.raceceiver.com](http://www.raceceiver.com)

*MYLAPS* website: [www.mylaps.com](http://www.mylaps.com)



**Airborne Park Speedway**

**Mailing Address: P.O. Box 786, AuSable Forks, NY 12912**

**Physical/GPS Address: 70 Broderick Road, Plattsburgh, NY 12901**

**Phone: (518) 647-4444 | Email: [info@airborneparkspeedway.com](mailto:info@airborneparkspeedway.com)**

**Website: [www.AirborneParkSpeedway.com](http://www.AirborneParkSpeedway.com)**

**Devil's Bowl Speedway**

**Mailing Address: 261 Randbury Rd., Rutland, VT 05701**

**Physical/GPS Address: 2743 Route 22A, West Haven, VT 05743**

**Phone: (802) 265-3112 | Email: [devilsbowlsspeedway@gmail.com](mailto:devilsbowlsspeedway@gmail.com)**

**Website: [www.DevilsBowlSpeedwayVT.com](http://www.DevilsBowlSpeedwayVT.com)**

# 1. RENEGADE SPECIFICATIONS

The Renegade division is meant to provide an enjoyable class of auto racing on a recreational level. These rules were created to protect the integrity of "traditional" stock car racing and make possible equal competition, and to encourage builders to use their imagination and skill – and not just money – in their efforts to build a winning racecar.

Because of the many types of automobiles that can be built under these rules, it is impossible for these rules to provide for every situation that might occur. Accordingly, management is given discretion, following the intent of the above goals, to rule on any matter not covered specifically in these guidelines. Airborne Park Speedway/Devil's Bowl Speedway reserves the right to make changes in these rules at any time, with or without notice, should changes become necessary to ensure greater safety or more equal competition.

Please understand that the Renegade division is currently in a rebuilding phase and is going to be considered a "work-in-progress". All cars that fit the general scope of the rulebook are welcome to race, but be advised that in the interest of fairness some changes may be made to individual cars based on performance, particularly with cars that dominate competition on a regular basis.

# 2. GENERAL RULES

1. The rules and/or regulations set forth herein are designed to provide for the orderly conduct of racing events and to establish minimum acceptable requirements for such events. These rules shall govern the condition of all events, and by participating in these events all participants are deemed to have obtained, read, understood, and complied with these rules. **NO EXPRESSED OR IMPLIED WARRANTY OF SAFETY SHALL RESULT FROM PUBLICATION OF OR COMPLIANCE WITH THESE RULES AND/OR REGULATIONS;** they are intended as a guide for the conduct of the sport and are in no way a guarantee against injury and/or death to a participant, spectator, or official. The interpretation and invoking of the rules published herein shall be determined by the officials at their professional discretion.
2. It is the responsibility of the competitor to obtain and become familiar with the current rules pertaining to the division in which he/she chooses to participate. The driver is as responsible as the owner, and it shall be the responsibility of both to know which parts are used in the race car that he/she owns and/or may be driving.
3. Any item not covered in these rules must remain stock or be approved in writing by Airborne Park Speedway/Devil's Bowl Speedway management. If any item being considered by a competitor is not addressed in these rules, the competitor is required to contact Airborne Park Speedway/Devil's Bowl Speedway management for a judgment as to its acceptability.
4. Technical Director and/or Track Manager will have final say on all rules, procedures, regulations, and/or technical authorities.
5. The safety of all drivers is paramount. A driver must display the ability to control his or her car and be able to keep pace with the field in order to maintain their regular handicap. All rookie and/or novice drivers will be evaluated on a case-by case-basis. Any driver that cannot keep pace with the field may be assigned a starting position at the rear of the field until he or she can display enough control and speed to compete and maintain a regular handicapped position.
6. Management reserves the right to add weight and/or a carburetor restrictor plate to any car at any time to ensure a level playing field.

# 3. CHASSIS SPECIFICATIONS

1. 1955 to present American-made hard top sedan or lift-back passenger car. Sunroofs and T-tops must be reinforced and enclosed. No convertibles. No Camaros or Firebirds. No front-wheel drive, 4-wheel drive, or rear engines.
2. Wheel base maximum 108.1" for full frame cars, maximum 110" for unibody cars.
3. **CARS MUST BE STRICTLY STOCK.** No cutting, chopping, channeling, shortening, etc., except front wheel wells may be removed. Body, hood, and trunk must be kept in place at all times. Stock steel unaltered floor pan and firewalls must be retained. Must be able to see original floorboard. No tin covering door bars.
4. If unibody car, complete bumper-to-bumper steel unibody must be retained. Rear frame may be plated as long as stock configuration is maintained, or replaced with 2" x 3" (only) square tubing from center of rear rearward.
5. Frames may be "X" braced. Unibodies must be tied – rear frame to front frame.
6. Inner tin on hoods, trunk lids, and door panels may be removed.
7. Stock hood and trunk latches must be removed with pins installed – minimum three in front of hood and two in rear of trunk. Handle on front of hood strongly recommended for fire/safety crew to easily grasp.
8. All bodies must appear stock – steel, aluminum, and fiberglass body parts and plastic nose/tail allowed. Aftermarket body parts allowed. No altering or channeling of stock or aftermarket parts allowed. Cars must be neat appearing - all sharp edges and torn panels must be repaired.

9. The 2015 season will be the final year that the Five Star Racecar Bodies "Fiberglass Sportsman" and/or "S2 Sportsman" bodies will be permitted. Five Star "Street Stock '88 Monte Carlo" body permitted and encouraged. This will be the only aftermarket body permitted beginning in 2016.
10. Replacement dashboard must be in factory stock location or as close to factory stock as possible.
11. All glass, plastic, upholstery, rear seat, lights, and chrome must be removed.
12. All doors must be secured shut (welded, chained, bolted, etc.).
13. Fenders may be reasonably trimmed for tire clearance only. All inner tin from hood, trunk lid and roof deck, and front and rear fenders may be removed.
14. No holes in hood. No ram air induction.
15. Door skirts are allowed. A 4" minimum clearance must be maintained. This rule is absolute.
16. Rear spoilers are allowed. Must be made of .090" minimum thickness aluminum with maximum width of 60" wide and 4" high. No side enclosure, no lips or bends in upper portion of spoiler. Spoiler must be flush to vertical surfaces of deck lid, non-adjustable.
17. Bumpers must be securely fastened to chassis to withstand impact. Bumper ends may not be braced.
18. Recommended tow hook front and rear. Minimum 5/16" chain.

#### 4. ROLL CAGE

1. Four-point cage required with door protection bars. Must be securely welded to frame. Roll cages will be inspected. See construction diagram at the back of this rulebook.
2. Roll cage must be made of 1-3/4" diameter x .095" minimum wall round steel tubing. Absolutely no square tubing or galvanized pipe allowed.
3. Rear main hoop of roll cage must be no closer than 26" from center of rear axle to back part of the upright on back part of the cage.
4. Horizontal bar required behind driver's seat to prevent seat from collapsing backward. Support for headrest and/or seatback extending up to support back of head is mandatory.
5. Minimum roll cage clearance 3" from driver's head.
6. A single front hoop within confines of body and no wider than stock frame rails may be attached to the main roll cage. It is to be parallel to the frame and have a maximum of four (4) uprights.
7. No internal reinforcement of bumpers allowed.
8. Fuel tank protection bar is mandatory, mounted frame rail to frame rail, no higher than the fuel cell and inside the trunk area. Bottom of fuel cell must be no lower than bottom frame rail.

#### 5. SAFETY

1. All cars must have an aluminum racing seat (full containment seat recommended, no fiberglass allowed) that must be fastened to roll cage, NOT bolted to the floorboard. Seat must be bolted in a minimum of six (6) spots to the roll cage using no less than 3/8" Grade 5 bolts.
2. Approved quick-release racing seat belts required. Belts must be in good condition, recommended to be not more than three (3) years old. Stock passenger seat belts not permitted. Seat belts must be properly bolted (not welded) to roll cage (see diagram). No cam lock seat belts allowed.
3. Approved driver window net mandatory – one inch (1") webbing minimum. Must be mounted on 3/8" steel rod, top and bottom. Must be attached at top front and bottom front by quick-release or seat belt-type latching device. Net must be taut when latched.
4. Splash guard required behind driver's head and shoulders – Lexan recommended.
5. Fully charged on-board fire extinguisher with working gauge required. Extinguisher must be mounted on crossbar on driver's right side with quick release (no taping), within reach of driver and accessible to safety crew from both left and right side windows.
6. Safety cut-off switch required on crossbar on driver's right side, within reach of driver and accessible to safety crew from both left and right side windows.
7. Battery must be mounted under hood and totally encased to prevent terminals from shorting out. Battery must be mounted in either stock location or in firewall under hood where heater core was located.
8. Fuel cell mandatory, mounted in trunk, 22-gallon maximum. **Fuel cell MUST be mounted in the center of the chassis, above the frame rails.**
9. In "traditional" Renegade cars, fuel cell must be mounted in trunk on top of frame rails.
10. Grandfathered Limited/Sportsman/Tiger cars must have fuel cell horizontally centered between frame rails, enclosed in 20 gauge steel container. Minimum height 12" from ground to bottom of steel container.
11. No plastic fuel filters allowed.
12. Driveshaft must be steel only and painted white. No aluminum driveshafts allowed.
13. Two 360° driveshaft loops are required. Must be constructed of at least 1/4" x 2" steel.

## 6. ENGINE

1. The only crate engine approved for use in the Renegade division at Airborne Park Speedway and Devil's Bowl Speedway is the General Motors "602" crate engine (Part # 88958602) with approved seals.
2. The following are approved engine builders for 2015:
  - RPM Racing Engines, 331 Carpenter Hill Road, Georgia, Vt. 05748. Phone: (802) 524-7406.
  - DMO Motors, 83 Bridge Street, Plattsburgh, N.Y. 12901. Phone: (518) 563-2749.
3. Only engines that have been logged into service and inspected by the approved engine builders will be eligible for competition. All engine work MUST be performed by the approved engine builders listed.
4. REGISTRATION: All teams are required to complete and submit an official Engine Registration form prior to competition. It is the responsibility of the driver and/or car owner to report any subsequent engine changes prior to competition. It is also the responsibility of the driver and/or car owner to report any engines or seals not already approved prior to competing.
5. PENALTIES: Violation of these rules will result in the following penalties:
  - a. Failure to report an engine or engine part change prior to competition – Minimum penalty: Disqualification from event; \$500 fine; driver suspended from competition until fine is paid.
  - b. Tampering with "spec" engine, fuel, or seals – Minimum penalties: Disqualification from event; \$1,000 fine; driver and/or car owner will lose all points accumulated in current season; driver and/or car owner will be suspended for one calendar or until fine is paid, whichever comes last.
  - c. Upon second offense, driver and/or car owner will be suspended for minimum of one calendar year and fined \$2,000. Multi-time violators may be suspended indefinitely.
6. All teams must be prepared at any time to remove engines to be inspected and/or Dynamometer checked at an independent site. Refusal to do so will result in disqualification.
7. OEM factory stock valve springs only – GM replacement Part # 19154761.
8. Any parts not listed in these rules must be factory stock.
9. Cars with crate engines not sealed by approved builder must add 100 lbs. There will be a three (3) event MAXIMUM grandfather clause for these engines before they must be resealed by an approved builder.
10. **NOTE: The only non-crate engines permitted in 2015 will be grandfathered engines that competed in 2014. MUST HAVE APPROVAL PRIOR TO COMPETITION – NO EXCEPTIONS.**

## 7. CARBURETOR

1. Two-barrel carburetors only. Maximum \$600.00 (list price) for carburetors.
2. No Demon carburetors allowed. No Holley Ultra HP carburetors allowed.
3. Holley 4412: Venturi size 1-3/8" and a maximum throttle bore of 1-11/16". No polishing anywhere that air flows. Choke horn cannot be removed. Venturi area must not be altered in any way. Stock butterflies only. Idle holes may be drilled out to .125". Throttle shaft must remain stock and may not be thinned in any way. A maximum 1-1/8" spacer height including gaskets between carburetor and intake. Must have two return springs on throttle.
4. No holes in hood. No ram air induction. Must be able to remove hood and air cleaner separately.
5. Five Star cold air boxes allowed, must be in stock configuration from factory. No additional air deflectors, cowls, sheet metal, hoses, tubes, inductors, or other add-ons allowed.

## 8. FUEL

1. Fuel rules to be announced prior to 2015 racing season.

## 9. EXHAUST

1. Muffler and exhaust systems are required. All cars must register under 95 decibels.
2. Factory steel headers or cast iron manifolds allowed. Stock OEM passenger car type only. No grinding, polishing, porting, acid porting, or any other alterations permitted.
3. The complete exhaust system must remain under car and exit to the rear behind driver's seat. No center dump type manifolds. Must remain dual exhaust, no crossover or "Y" pipes allowed.
4. Maximum exhaust pipe diameter is 3".
5. Primary pipes must maintain a 1-5/8" diameter from flange to collector. Crossover headers (not 180° headers) are allowed with primary pipes that maintain a 1-5/8" diameter from flange to collector. Maximum header flange or adapter flange thickness is 3/8".
6. Mufflers are recommended. Only stock or "California Turbo" mufflers will be allowed. The use of round glass pack type mufflers is allowed. Mufflers may not be altered or modified from original design in any way.
7. Tri-Y, 180° headers, step headers, stainless steel, coated, ceramic and/or otherwise, and/or merge collectors not permitted. No powder coated or exotic type headers, with the exception of regular paint.
8. No exhaust pieces may be welded. All pieces must be removable and able to be inspected.

## 10. IGNITION

1. Stock HEI ignition coil only. No dual point ignition. Must remain stock as purchased from GM.
2. GM factory distributor only – Part # 93440806. Only modification allowed is removal of vacuum adjustment.
3. The distributor advance curve and/or all parts must remain stock as manufactured.

## 11. COOLING SYSTEM

1. Any stock passenger car type radiator. Aluminum radiator allowed but must be stock passenger car type.
2. Overflow tubes must be directed to the lower right corner of windshield or wind screen.
3. Conventional and electric fans are allowed.

## 12. TRANSMISSION

1. Only manual transmissions that were used in cars that competed in 2014 will be permitted in those same cars in 2015. Manual transmissions are not a “new” alternative option at this time – stock automatic transmission must be used if car is equipped with such.
2. Only steel parts allowed in clutch and driveline. No aluminum, magnesium, titanium, or other materials.
3. Steel scatter-proof 360° bellhousing required. Minimum 1-3/4” (2” maximum) inspection hole mandatory, drilled in bottom of bellhousing.
4. All gears must be in working order.
5. Transmission cross member not required, however rubber or solid mount for transmission is required.
6. AUTOMATIC:
  - a. Stock three-speed, must remain OEM stock – Turbo 350 and C4 only. No Turbo 400, C6, 727, or any other model. No Powerglides. No two-speed, four-speed, or special racing automatics.
  - b. Stock 12” torque converter only.
7. MANUAL:
  - a. Stock three-speed only. Standard stock clutch (10.4”) and flywheel assembly only.
  - b. One clutch, one diaphragm-type pressure plate only. No lightening of pressure plate. No aluminum pressure plates allowed – must be completely steel.
  - c. Flywheel must be steel only and weigh minimum 20 lbs.
  - d. Hydraulic throw-out bearings allowed.

## 13. REAR END

1. Must be stock only. GM limited slip, welded rears, spools allowed. No Detroit lockers.
2. No truck rear ends allowed. Trailing arms must be one piece non-adjustable steel.
3. Nine inch (9”) Ford rear allowed in grandfathered Limited/Sportsman/Tiger cars only. (Five-bolt pattern only.)
4. Rear end gear ratios allowed are 3.42 to 3.73.
5. Maximum 5:14 rear end gear allowed on grandfathered Limited/Sportsman/Tiger cars ONLY.

## 14. SUSPENSION

1. Must be OEM suspension with all stock ball joints and suspension components. Basic reinforcing (double nuts, washers, etc.) is allowed. No other modifications allowed unless noted.
2. **Tread width must remain stock for GM metric chassis.** Maximum tread width on grandfathered Limited/Sportsman/Tiger cars will be 60.5”. Note that this may be adjusted at any time.
3. Minimum frame height of 6” with driver in seat.
4. Cars with jacking bolts must have jacking bolts backed off to maximum height with NO adjustability – bolts must be locked, welded, etc. Jacking bolts will be marked prior to competition.
5. A maximum 1-1/4” front anti-roll (sway) bar is allowed in stock location. Use of threaded rod to connect sway bar to A-arms is permitted. No rear sway bars (*except for Metal Man!*).
6. All springs must be stock appearing and mounted in stock factory position. Springs may be cut. Aftermarket front and rear springs allowed. Front spring rates up to 1,000 lbs. maximum allowed. Rear spring rates up to 225 lbs. maximum allowed. Minimum front spring height 11”, minimum rear spring height 12”.
7. Any aftermarket tubular upper A-arms are approved for use. Must be one piece steel non-adjustable. Cross shaft must be steel only. Stock type ball joint only.
8. No spring spacers, lumber, or chains allowed to alter stock suspension. Maximum two (2) per spring factory stock rubber spring pocket donuts may be used in stock location in “traditional” Renegade cars. Grandfathered Limited/Sportsman/Tiger cars may not use any type of spacers, lumber, chains, or donuts, stock or otherwise.
9. Shocks must be stock factory type. Pro, Bilstein & AFCO stock replacement shocks allowed. Must be mounted in stock mounting position. Any other brand of replacement shock MUST be approved by the track. Price limit is \$75.00 (list price) per shock.

10. All steering components must remain stock. Stock drag links only.
11. Safety hub required on right front wheel (heavy duty Impala style) and encouraged for left front as well. Right front hub must be solid steel only.
12. Spindles must be stock Monte Carlo style. No drop spindles. No Impala spindles.
13. Neoprene bushings are allowed.

## 15. BRAKES

1. Brakes on all four wheels must work at all times. Brakes will be checked.
2. No rear disc brakes allowed in "traditional" Renegade cars. Rear disc brakes allowed on grandfathered Limited/Sportsman/Tiger cars only.
3. All brake parts must be OEM factory stock style. No racing style brake parts allowed.
4. S-10 or Toyota slave cylinder setup or one of the same allowed. No aftermarket.
5. Brake cooling ducts are allowed.

## 16. TIRES & WHEELS

1. Official track tire will be mandatory.
2. Racing wheels only. Must be 15" x 7" only and must weigh minimum 22 lbs. Wheels allowed with a 3-1/2" maximum offset only, and all four wheels must be same offset.
3. One inch (1") lug nut mandatory on all studs. No exceptions.
4. Chemical treating of tires will not be allowed. No shaving of any tires allowed. A durometer rule will be in effect regarding minimum tire hardness. Durometer numbers will be determined and announced to competitors prior to first event.
5. Tire clean-up with scraper blades allowed. No form of any liquid allowed to clean tires.
6. Questionable tires, or tires not meeting above criteria as determined by officials, may be confiscated by officials and could result in disqualification and/or other penalties.

## 17. WINDOWS

1. All vehicles must have a full Lexan or OEM glass windshield. Must be clear and supported by one upright brace in center, with minimum thickness of 1/8".
2. B-pillar window openings may be covered with clear Lexan only.
3. Rear Lexan windshield permitted as part of Five Star '88 Monte Carlo body package ONLY. No other bodies may run a rear windshield.
4. No Plexiglas allowed.

## 18. WEIGHT

1. Management reserves the right to change weight rules for any car at any time in the interest of competition and parity.
2. Minimum total weight 3,200 pounds with driver in seat.
3. All cars with non-sealed engines must add 100 lbs.
4. Left side maximum 53% with driver in seat. **Maximum cross weight for ALL cars is 53.0%.**
5. All added ballast must be made of lead – no other materials permitted.
6. Ballast must be painted white with car number highly visible on ballast in black.
7. Ballast must be 5 lbs. minimum, bolted securely to frame rails and in plain view. All ballast must be located ahead of centerline of rear axle and above or on inside of factory frame rails. No ballast may be hung beyond width of original factory frame rails, or below frame. No ballast may be mounted inside car.

**ALL RULES SUBJECT TO CHANGE WITH OR WITHOUT NOTICE.**  
**EIRI 05-17-15 (revised 5-17-15)**  
**Devil's Bowl Speedway © 2015**



### 4-Point Roll Cage

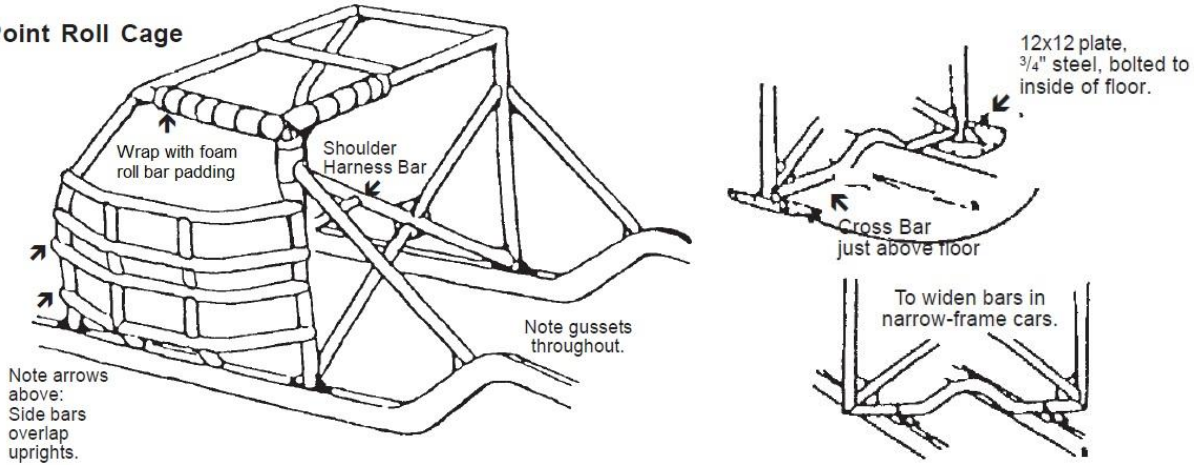

### Recommended Seat Belt Installation

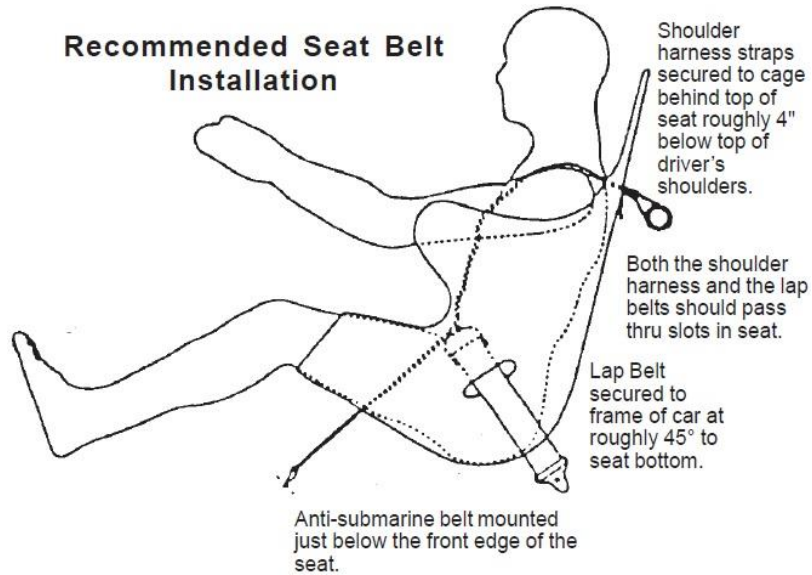

### Tank Installation #1 Renegade/Mini Stock

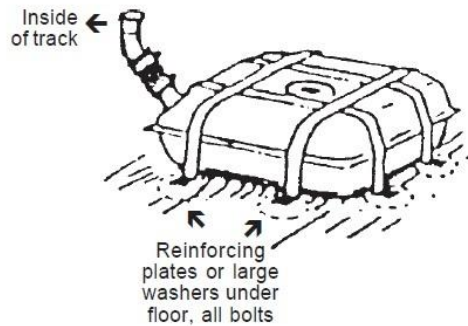

### Fuel Line Protection

