



2016

OFFICIAL RULES & REGULATIONS ENDURO SERIES DIVISION

NOTE: CHANGES FROM PREVIOUS YEAR *WRITTEN IN RED*

It is strongly recommended that all Enduro Series drivers be equipped with a working RACEceiver-type one-way scanner unit.
RACEceiver website: www.raceceiver.com

Devil's Bowl Speedway
Mailing Address: 261 Randbury Rd., Rutland, VT 05701
Physical/GPS Address: 2743 Route 22A, West Haven, VT 05743
Phone: (802) 265-3112 | Email: devilsbowlspeedway@gmail.com
Website: www.DevilsBowlSpeedwayVT.com

1. SAFETY:

1. Helmet required for driver. Full-face helmet (with minimum certification of Snell SA 2010, SFI 31.1/2005, or FIA 8860-2010) highly recommended. Compatible head-and-neck restraint system highly recommended.
2. Driver MUST wear full-length sleeves and pants, with closed-toe shoes. Fire retardant suits highly recommended for driver, minimum SFI specification 3.2A/5. Multi-layer suits, gloves, shoes, socks, and underwear highly recommended.
3. All cars MUST have a roll cage with four (4) uprights. Must have minimum three (3) padded door bars on driver's side, and minimum two (2) door bars or one "X" on passenger's side. Cage must be constructed of round steel tubing, minimum 1-3/4" diameter, and minimum .095" wall thickness. All welds must be professional, strong, and complete with no cracks. Roll bars must have professional bends with no kinks or cracks. Rear support bars permitted, must tie to frame or floor in front of rear axle. No bars allowed in front of firewall or behind rear axle.

ENDURO SERIES ROLL CAGE KIT SPECIAL OFFER:

Devil's Bowl Speedway has secured a special discount price for Enduro Series competitors to purchase approved roll cage kits (51" wide) from Roll Cage Components of Amelia, VA. Mention the Devil's Bowl Speedway Enduro Series division for a base price of \$175.00 plus shipping.

Roll Cage Components

Phone: (804) 598-4200

Website: www.RollCageComponents.com

P.O. Box 561

Amelia, VA 23002

4. Window net and aluminum racing seat recommended. Fiberglass seats not allowed.
5. Quick-release racing seat belts required, minimum three-inch width, SFI 16.5-approved. Belts must be in good condition, no more than five (5) years old from date of manufacture. Stock passenger seat belts no longer permitted. Seat belts must be properly bolted (not welded) to roll cage (see diagram). No cam lock seat belts allowed.
6. Working fire extinguisher, securely mounted in center of car and accessible from all sides MANDATORY. No taping allowed.

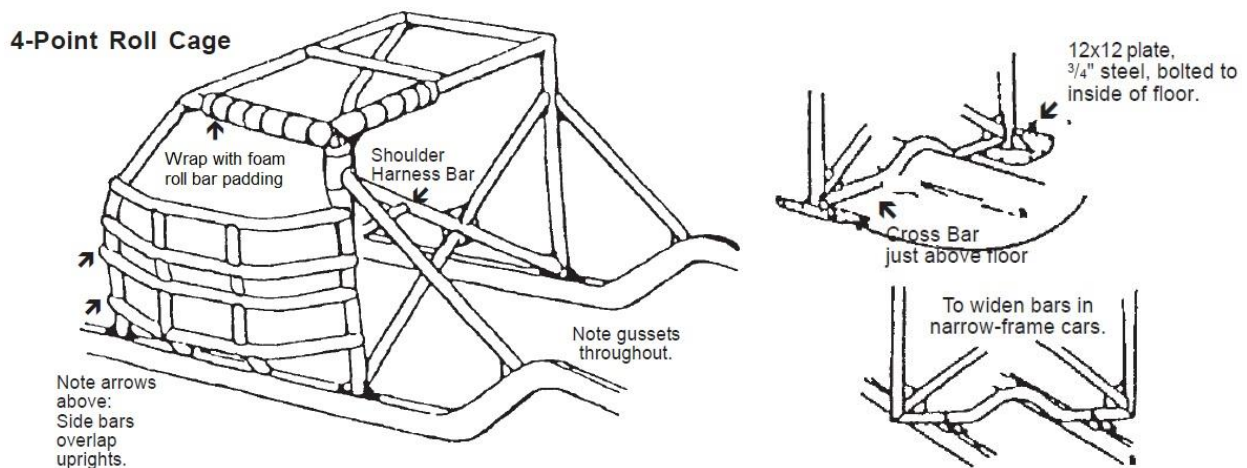

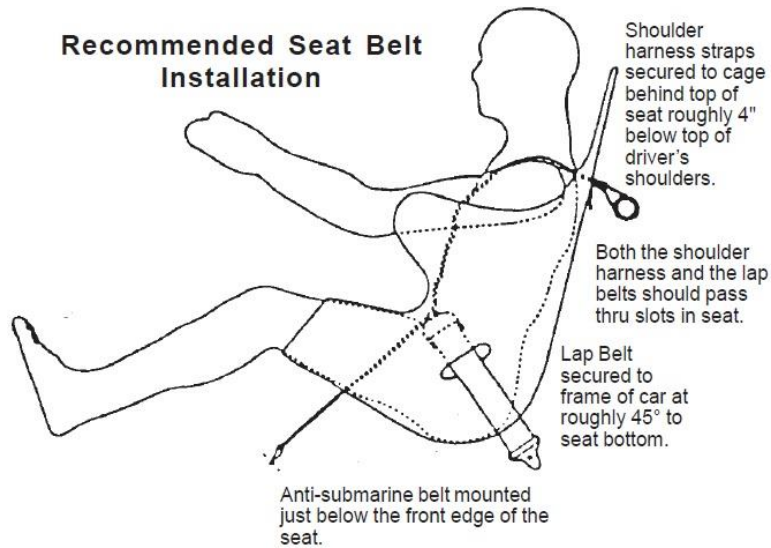

2. BODY/CHASSIS/ENGINE:

1. Any domestic or import sedan, coupe, hatchback, station wagon, light-duty pickup truck, or mini-van allowed. No sports cars, full-size trucks, full-size vans, or SUVs. No convertibles. T-tops must be covered with metal.
2. Engine must be 4-cylinder or 6-cylinder. No turbos, intercoolers, or superchargers. No all-wheel-drive or four-wheel-drive. ALL ENGINE COMPONENTS MUST REMAIN STOCK!
3. Maximum wheelbase 110".
4. All suspension components MUST REMAIN STOCK! Springs, shocks, struts, control arms, spindles, sway bars, trailing arms, axles, etc.... STRICTLY STOCK!
5. All glass must be removed. Windshield may remain stock glass or be replaced with Lexan or screen. No Plexiglas. Windshield or screen must be braced in the middle.
6. All headlights, taillights, and directional signals must be removed. Center brake light optional.
7. Passenger seats and upholstery must be removed. Rear seatback must remain as firewall or be replaced with tin.
8. Fuel tank must remain stock and in stock location. Tank must be secured by two (2) metal straps. Tank may be replaced with racing-type fuel cell, securely mounted.
9. Battery must remain stock and in stock location. Battery must be secured by one (1) metal strap and covered with rubber to prevent arc/sparking.
10. Hood and trunk must be fastened with minimum two (2) hood pins. Doors must be welded or chained shut.
11. Bumpers must have two (2) safety straps or chains connected to main frame. Tow hook or chain MANDATORY on both front and rear bumpers.
12. Appearance: Numbers must be clearly displayed on doors and roof, in contrasting color to body. No offensive lettering, pictures, or other signage. "Shark fin" or other device displaying number on roof is optional—MUST BE SECURELY MOUNTED.
13. No racing parts, engines, tires, wheels, or other components, aside from safety modifications. THESE ARE NOT INTENDED TO BE RACECARS!
14. Current or former drivers of regular racing divisions will be evaluated on an individual basis before being permitted to compete, and may be subject to handicapping.

3. RACE PROCEDURE:

1. ALL CARS MUST PROVIDE A CLOCK SCORER. Scorer's meeting will be held prior to start of event at a time to be announced.
2. Green flag laps only. Race will only be stopped by red flag in case of a dangerous situation. No yellow flags.

3. Race distance will be as advertised, unless otherwise noted in driver meeting. Race will be deemed official one lap after halfway.
4. Race purse will be announced prior to race. ***Payout subject to change dependent on number of entries.***

4. CHAMPIONSHIP STRUCTURE:

1. Points will be given to all drivers in all events. Winner will receive 50 points, 2nd place 48 points, 3rd place 46 points, etc., with a two-point declination for each subsequent position. Minimum will be 10 points for drivers finishing 21st or worse.

Points distribution:

1 st – 50 pts.	5 th – 42	9 th – 34	13 th – 26	17 th – 18	21 st – 10
2 nd – 48	6 th – 40	10 th – 32	14 th – 24	18 th – 16	22 nd – 10
3 rd – 46	7 th – 38	11 th – 30	15 th – 22	19 th – 14	23 rd – 10
4 th – 44	8 th – 36	12 th – 28	16 th – 20	20 th – 12	24 th – 10

All others receive 10 points.

2. Registered drivers unable to start race may receive last-place points.
3. Registered drivers who do not return a score card may receive last-place points.
4. Cars do not accumulate points. Drivers may use multiple cars during season.
5. The driver with the most points after the final Enduro Series race will be declared the champion. Ties for final overall position – except for the champion – will not be broken. In the event of a tie for the championship, the tie will be broken based on the following criteria:
 - a. Number of wins.
 - b. Number of 2nd-place finishes, 3rd-place finishes, etc.
 - c. If all finishes between tied drivers are identical, the highest finishing driver in the final completed Enduro Series event will be the champion.

***ALL RULES SUBJECT TO CHANGE WITH OR WITHOUT NOTICE. EIRI 3/01/16
Devil's Bowl Speedway © 2016***

CONTACT INFORMATION:

Mailing Address: Devil's Bowl Speedway, 261 Randbury Rd., Rutland, VT 05701

Phone: (802) 265-3112

Fax: (802) 773-0147

Email: devilsbowl Speedway@gmail.com