



2019

OFFICIAL RULES & REGULATIONS SUPER STOCK

*NOTE: CHANGES FROM PREVIOUS YEAR WRITTEN IN RED
CHANGES MADE ON 6/14/19 HIGHLIGHTED IN YELLOW*

All cars **MUST** be equipped with a working RACEceiver-type one-way scanner
and a working MYLAPS timing transponder.

RACEceiver website: www.raceceiver.com

MYLAPS website: www.mylaps.com

Devil's Bowl Speedway
Mailing Address: 261 Randbury Rd., Rutland, VT 05701
Physical/GPS Address: 2743 Route 22A, West Haven, VT 05743
Phone: (802) 265-3112 | Email: devilsbowl Speedway@gmail.com
Website: www.DevilsBowlSpeedwayVT.com

1. SUPER STOCK SPECIFICATIONS

The Super Stock division is meant to provide an enjoyable class of auto racing on a “hobby” level. All cars that fit the general scope of this rulebook are welcome to race, however, be advised that in the interest of fairness and parity some changes may be made to individual cars based on performance, particularly with cars that dominate competition on a regular basis.

Because of the many types of automobiles that may be built using these rules, it is improbable for these rules to detail every situation that might occur. Accordingly, management is given discretion to rule on any matter not covered specifically in these guidelines. Devil’s Bowl Speedway reserves the right to make changes in these rules at any time, with or without notice, should changes become necessary to ensure greater safety or more equal competition.

2. GENERAL RULES

1. The rules and/or regulations set forth herein are designed to provide for the orderly conduct or racing events and to establish minimum acceptable requirements for such events. These rules shall govern the condition of all events, and by participating in these events all participants are deemed to have obtained, read, understood, and complied with these rules. NO EXPRESSED OR IMPLIED WARRANTY OF SAFETY SHALL RESULT FROM PUBLICATION OF OR COMPLIANCE WITH THESE RULES AND/OR REGULATIONS; they are intended as a guide for the conduct of the sport and are in no way a guarantee against injury and/or death to a participant, spectator, or official. The interpretation and invoking of the rules published herein shall be determined by the officials at their professional discretion.
2. It is the responsibility of the competitor to obtain and become familiar with the current rules pertaining to the division in which he/she chooses to participate. The driver is as responsible as the owner, and it shall be the responsibility of both to know which parts are used in the race car that he/she owns and/or may be driving.
3. Any item not covered in these rules must remain stock or be approved in writing by Devil’s Bowl Speedway. If any item being considered by a competitor is not addressed in these rules, the competitor is required to contact management for a judgment of its acceptability.
4. Technical Director and/or Track Manager will have final say on all rules, procedures, regulations, and/or technical authorities.
5. Safety is paramount. A driver must display the ability to control his or her car and be able to keep pace with the field in order to maintain their regular handicap. All rookie and/or novice drivers will be evaluated on a case-by case-basis. Any driver that cannot keep pace with the field may be assigned a starting position at the rear of the field until he or she can display enough control and speed to compete and maintain a regular handicapped position.
6. Management reserves the right to add weight and/or change percentages to any car at any time, and/or to adjust other rules governing any car to ensure a level playing field.

3. CHASSIS, BODY, & INTERIOR SPECIFICATIONS

1. Any American-made hard top sedan or lift-back passenger car permitted, 1955 to present. Sunroofs and T-tops must be reinforced and enclosed. No convertibles. No front-wheel drive, 4-wheel drive, or rear engines. Camaro, Firebird, Mustang, and similar models must receive approval prior to competing. Other non-production and/or unconventional bodies must receive approval prior to competing.
2. Wheel base maximum 108.1” for full frame cars, maximum 110” for unibody cars. Contact officials with questions concerning other vehicles including tube chassis cars.
3. Complete bumper-to-bumper steel unibody must be retained on unibody cars. Rear frame may be plated as long as stock configuration is maintained, or replaced with 2” x 3” (only) square tubing from center of rear rearward.
4. Frames may be “X” braced. Unibodies must be tied – rear frame to front frame.
5. Inner tin on hoods, trunk lids, and door panels may be removed.
6. Stock hood and trunk latches must be removed with pins installed – minimum three in front of hood and two in rear of trunk. Handle on front of hood strongly recommended for fire/safety crew to easily grasp. No Dzus-type fasteners allowed on hood and trunk.

7. All bodies must appear stock – steel, aluminum, and fiberglass body parts and plastic nose/tail allowed. Aftermarket body parts allowed. No altering or channeling of stock or aftermarket parts allowed. Cars must be neat appearing - all sharp edges and torn panels must be repaired. Contact officials with questions.
8. Replacement dashboard must be in factory stock location.
9. All glass, plastic, upholstery, rear seat, lights, and chrome must be removed.
10. No mirrors allowed.
11. All doors must be secured shut (welded, chained, bolted, etc.).
12. Fenders may be reasonably trimmed for tire clearance only. All inner tin from hood, trunk lid and roof deck, and front and rear fenders may be removed.
13. No holes in hood. No ram air induction.
14. Door skirts are allowed. A 4" minimum clearance must be maintained. This rule is absolute.
15. Rear spoilers allowed. Side enclosures allowed – maximum 6" long and 4" high, mounted 90° perpendicular to spoiler blade and 90° perpendicular to deck lid/tailpiece. All material must be minimum .090" thickness aluminum. Maximum spoiler width 60" including enclosures, maximum spoiler blade material height 4". No lips or bends, no fins in middle of spoiler. Spoiler must be non-adjustable, mounted flush to vertical surfaces of deck lid/tailpiece.
16. Bumpers must be securely fastened to chassis to withstand impact. Bumper ends may not be braced. Recommended tow hook front and rear. Minimum 5/16" chain.
17. Cars without rear bumper covers must have full tin enclosure surrounding fuel cell.
18. Interior tin may be added for "cockpitting." All work must be neat with no sharp edges and must not impede driver's emergency escape routes. Technical inspectors will have sole discretion. Contact Devil's Bowl Speedway officials with questions.
19. All cars must have a working MYLAPS-brand transponder mounted on right-side of right-rear frame rail. Transponder must be securely fastened, mounted vertically with sensor pointing down to race track. Centerline of transponder must be located 12" behind the rear edge of the rear axle tube, not more than 12" high from the ground. Any car without a working transponder is subject to being omitted from finish order. (The MYLAPS "X2" transponder is highly recommended. Visit www.MYLAPS.com for more information.)

4. ROLL CAGE

1. Four-point cage required with door protection bars. Must be securely welded to frame. Roll cages will be inspected. See construction diagram at the back of this rulebook.
2. Roll cage must be made of 1-3/4" diameter x .095" minimum wall round steel tubing. Absolutely no square tubing or galvanized pipe allowed.
3. Rear main hoop of roll cage must be no closer than 26" from center of rear axle to back part of the upright on back part of the cage.
4. Horizontal bar required behind driver's seat to prevent seat from collapsing backward. Support for headrest and/or seatback extending up to support back of head is mandatory.
5. Minimum roll cage clearance 3" from driver's head.
6. Single front hoop within confines of body, no wider than stock frame rails may be attached to main roll cage. Must be parallel to frame and have a maximum of four (4) uprights.
7. No internal reinforcement of bumpers allowed.
8. Fuel tank protection bar mandatory, mounted frame rail to frame rail, no higher than the fuel cell and inside trunk area. Bottom of fuel cell must be no lower than bottom frame rail.

5. SAFETY

1. All cars must have an aluminum racing seat (full containment seat recommended, no fiberglass allowed) that must be fastened to roll cage, NOT bolted to floorboard. Seat must have four (4) bolts in seat pan mounted to roll cage and two (2) bolts on headrest/seatback area mounted to roll cage, using no less than 3/8" Grade 5 bolts. NO EXCEPTIONS.
2. Approved quick-release racing seat belts required. Belts must be in good condition, recommended to be not more than three (3) years old. Stock passenger seat belts not

permitted. Seat belts must be properly bolted (not welded) to roll cage (see diagram). No cam lock seat belts allowed.

3. Approved driver window net mandatory – one-inch (1”) webbing minimum. Must be mounted on 3/8” steel rod, top and bottom. Must be attached at top front and bottom front by quick-release or seat belt-type latching device. Net must be taut when latched.
4. Splash guard required behind driver’s head and shoulders – Lexan recommended.
5. Fully charged on-board fire extinguisher with working gauge required. Extinguisher must be mounted on crossbar on driver’s right side with quick release (no taping), within reach of driver and accessible to safety crew from both left and right side windows.
6. Safety cut-off switch required on crossbar on driver’s right side, within reach of driver and accessible to safety crew from both left and right side windows.
7. Battery must be mounted under hood and totally encased to prevent shorting. Battery must be mounted in either stock location or in firewall under hood where heater core was located.
8. Fuel cell mandatory, mounted in trunk, 22-gallon maximum. In stock frame cars, fuel cell must be mounted in trunk above frame rails. In tube frame cars, fuel cell must be horizontally centered between frame rails, enclosed in 20-gauge steel container; minimum height 12” from ground to bottom of steel container.
9. No plastic fuel filters allowed.
10. Driveshaft must be steel only and painted white. No aluminum driveshafts allowed.
11. Two 360° driveshaft loops are required. Must be constructed of at least 1/4” x 2” steel.

6. ENGINE

1. All teams are required to complete and submit an official Engine Registration Form prior to competition. It is the responsibility of the driver and/or car owner to report any subsequent engine changes prior to competition. It is also the responsibility of the driver and/or car owner to report any engines or seals not already approved prior to competing.
2. Cars with “built” engines or unsealed crate engines will be subject to penalties including but not limited to 100 lbs. added weight. (*See: Section 18 – Weight*)
3. All teams must be prepared at any time to remove engines to be inspected and/or dynamometer checked at an independent site designated by Devil’s Bowl Speedway. Refusal to do so will result in disqualification and/or additional penalties.
4. **OPTION #1 – GENERAL MOTORS “602” CRATE ENGINE**
 - a. The only crate engine approved for use in the Super Stock division is the General Motors “602” crate engine (Part #88958602 or #19258602). Crate engine must have approved factory GM seal and/or seals from one of the following approved builders:
 - RPM Racing Engines, 331 Carpenter Hill Road, Georgia, Vt. 05748. Phone: (802) 524-7406. Website: www.rpmenginesvt.com
 - Hunt’s Machine, 102 Weaver Street Schenectady, N.Y. 12305. Phone: (518) 372-7273. Website: www.huntsmachine.com
 - b. PENALTIES: Violation of these rules will result in the following penalties:
 1. Failure to report an engine or engine part change prior to competition – Minimum penalty: Disqualification from event; \$500 fine; driver suspended from competition until fine is paid.
 2. Tampering with engine, fuel, or seals – Minimum penalties: Disqualification from event; \$1,000 fine; driver and/or car owner will lose all points accumulated in current season; driver and/or car owner will be suspended for one calendar year or until fine is paid, whichever comes last.
 3. Second offense: driver and/or car owner suspended minimum one calendar year and fined \$2,000. Multi-time violators may be suspended indefinitely.
 - c. OEM factory stock valve springs only – GM replacement Part #19154761.
 - d. Any parts not listed in these rules must be factory stock.
5. **OPTION #2 – “BUILT” ENGINE**
 - a. Maximum cubic inch limit is 360 for all cars. Engine must remain stock for vehicle. (Exception: Chevrolet 350 CID engine may replace any other Chevrolet V8.)

- b. No removal or alterations to casting numbers allowed on any engine part.
- c. All engines are allowed .040" overbore for clean-up and/or wear.
- d. **CRANKSHAFT**
 - 1. No lightening holes, O.D., trimming, or any other lightening features. Oil holes may be chamfered.
 - 2. Main bearing diameter 2.448.
 - 3. Crankshaft must be stock for engine.
 - 4. Connecting rod journal diameter 2.100.
 - 5. Minimum weight 48 lbs.
 - 6. All throws and counter weights must not be narrowed or knife-edged. No center cutting on counter weights. No holes through crank pins.
 - 7. Machined steel crank pulley allowed. No aluminum.
- e. **PISTONS**
 - 1. Flat-top pistons allowed. Domed pistons NOT allowed.
 - 2. Cast pistons must be Full Skirt, matching four eyebrows and three rings in stock location.
 - 3. Chevrolet must use stock OEM cast or cast replacement pistons.
- f. **RODS**
 - 1. Stock OEM connecting rods must be used. No modifications allowed.
 - 2. Aftermarket rod bolts allowed. Must be 5.7 length.
- g. **CYLINDER HEADS**
 - 1. Stock OEM iron heads allowed.
 - 2. Double humped heads allowed.
 - 3. No guide plates allowed.
 - 4. No Vortec, Bow Tie, Dart, Brodix, etc., allowed.
 - 5. No aluminum heads allowed.
 - 6. No angle plug heads allowed.
 - 7. No angle milling allowed. No more than 3 cc's can be flat machined or ground from gasket surface of cylinder heads. Factory cc specs will be used as guidelines.
 - 8. Valve stem diameter to .343" +/- .005". Intake valve head diameter not to exceed 1.940". Exhaust valve diameter not to exceed 1.500".
 - 9. Screw-in studs allowed. No poly locks.
- h. **CAMSHAFT**
 - 1. Hydraulic cams and lifters only. No roller cams or lifters.
 - 2. Camshaft lift may be measured at the valve rocker arm. Maximum valve lift will be as follows:

<u>Engine</u>	<u>Intake</u>	<u>Exhaust</u>
Buick	.402	.418
Chevrolet	.390	.410
Chrysler	.429	.444
Ford Cleveland	.461	.463
Ford Windsor	.427	.465
Oldsmobile	.450	.450
Pontiac	.400	.410
- i. **ROCKER ARMS**
 - 1. Stock rockers and ratio (1.5) must be maintained. Long slot rockers allowed.
 - 2. Chevrolet rockers must have triangular insignia.
 - 3. No guide plates.
- j. **INTAKE MANIFOLD**
 - 1. Stock cast iron two-barrel intake for year, make, and model. No aluminum.
 - 2. Maximum thickness of gaskets and spacer (if used) must not exceed a total of 1/4", measured from the base of the carburetor to the top of the intake manifold.
- k. **FUEL PUMP**
 - 1. Stock OEM stamped steel bowl-type pups only.
 - 2. No Holley style.

I. OILING SYSTEM

1. No racing oil pans.
2. 1" diameter inspection plug mandatory.

7. CARBURETOR

1. Two-barrel carburetors only. Maximum \$850.00 (list price) for carburetors.
2. No Demon carburetors allowed. No Holley Ultra HP carburetors allowed.
3. Holley 4412: Venturi size 1-3/8" and a maximum throttle bore of 1-11/16". No polishing anywhere that air flows. Choke horn cannot be removed. Venturi area must not be altered in any way. Stock butterflies only. Idle holes may be drilled out to .125". Throttle shaft must remain stock and may not be thinned in any way. A maximum 1-1/8" spacer height including gaskets between carburetor and intake. Must have two return springs on throttle.
4. Carburetor spacer plate must be one-inch (1") maximum thickness. Must be Bicknell part number BRP377, or original CVRA spec, or phenolic material. No alterations whatsoever. No tapered spacers, no Super Suckers or similar.
5. No holes in hood. No ram air induction. Hood and air cleaner must be separate.
6. Five Star cold air boxes allowed, must be in stock configuration from factory. No additional air deflectors, cowls, sheet metal, hoses, tubes, inductors, or other add-ons allowed.

8. FUEL

1. Maximum octane 98 fuel. No additives or other fuels permitted. No Crate Extreme or other high-dollar fuels permitted.

9. EXHAUST

1. Factory steel headers or cast-iron manifolds allowed. Stock OEM passenger car type only. No grinding, polishing, porting, acid porting, or any other alterations permitted. **No homebuilt headers permitted.**
2. Complete exhaust system must remain under car and exit to rear behind driver's seat. No center dump type manifolds. Must remain dual exhaust, no crossover or "Y" pipes allowed.
3. Maximum exhaust pipe diameter is 3".
4. Primary pipes must maintain a 1-5/8" diameter from flange to collector. Crossover headers (not 180° headers) are allowed with primary pipes that maintain a 1-5/8" diameter from flange to collector. Maximum header flange or adapter flange thickness is 3/8".
5. Mufflers are recommended. Only stock or "California Turbo" mufflers will be allowed. The use of round glass pack type mufflers is allowed. Mufflers may not be altered or modified from original design in any way.
6. Tri-Y, 180° headers, step headers, stainless steel, coated, ceramic and/or otherwise, and/or merge collectors not permitted. No powder coated or exotic type headers.
7. No exhaust pieces may be welded. All pieces must be removable and able to be inspected.

10. IGNITION

1. Stock HEI ignition coil only. No dual point ignition. Must remain stock from GM.
2. All 602 crate engines are strongly recommended to use MSD Part # 87286 Ignition Box with a 6,000 rpm rev chip, or MSD Part # 8727CT Ignition Box limited to 6,000 rpm. Box and rev chip must remain operable and in working condition prior to, during, and after all racing events. Rev chip must be face up and securely fastened (taped in).
3. Rev box and coil must be mounted in engine compartment, under hood, out of reach of driver. Ground wire must be mounted to back of intake manifold. When hood is removed, rev box and all wires must be uncovered and clearly visible. (See diagram.)
4. GM factory distributor ONLY – Part # 93440806. The ONLY modification allowed is the removal of the vacuum adjustment.
5. The distributor advance curve and/or all parts must remain stock as manufactured.

11. COOLING SYSTEM

1. Any stock passenger car type radiator. Aluminum radiator allowed.
2. Overflow tubes must be directed to the lower right corner of windshield or wind screen.
3. Conventional and electric fans are allowed.

12. TRANSMISSION

1. Only steel parts allowed in clutch and driveline. No aluminum, magnesium, titanium, or other materials.
2. Steel scatter-proof 360° bellhousing required. Minimum 1-3/4" (2" maximum) inspection hole mandatory, drilled in bottom of bellhousing.
3. All gears must be in working order.
4. Transmission cross member not required, however rubber or solid mount for transmission is required.
5. AUTOMATIC:
 - a. Stock three-speed, must remain OEM stock – Turbo 350 and C4 only. No Turbo 400, C6, 727, or any other model. No Powerglides. No two-speed, four-speed, or special racing automatics.
 - b. Stock 12" torque converter only.
6. MANUAL:
 - a. Stock three-speed only. Standard stock clutch (10.4") and flywheel assembly only.
 - b. One clutch, one diaphragm-type pressure plate only. No lightening of pressure plate. No aluminum pressure plates allowed – must be completely steel.
 - c. Flywheel must be steel only and weigh minimum 15 lbs. with bolts. GM "602" crate engine must use GM flywheel Part #14088646 (15 lbs.) or GM flywheel Part #14088650 (25 lbs.).
 - d. Hydraulic throw-out bearings allowed.

13. REAR END

1. Stock only. GM limited slip, welded rears, spools, and floaters allowed. No Detroit lockers.
2. No truck rear ends allowed. Trailing arms must be one-piece, non-adjustable steel.
3. Nine-inch (9") Ford rear allowed. (Five-bolt pattern only.)

14. SUSPENSION

1. Must be OEM suspension with all stock ball joints and components. Basic reinforcing (double nuts, washers, etc.) is allowed. No other modifications allowed unless noted.
2. Maximum tread width 68.5" for all cars – no tolerance. Measured from outer bead of wheels.
3. Minimum frame height is 6" with driver in seat, race ready.
4. Adjustable jacking bolts are approved for all cars on all four springs. Adjustable spring cups allowed. Spring spacers (including spring rubbers) allowed. No lumber or chains allowed.
5. A maximum 1-1/4" front anti-roll (sway) bar is allowed in stock location. Use of threaded rod to connect sway bar to A-arms is permitted. No rear sway bars.
6. Rear suspension must be 4-link system. No 3-link systems allowed.
7. Regular "big spring" coil springs only. No leaf springs. No coilover shocks.
8. All coil springs must be stock appearing and mounted in stock factory position. Springs may be cut. Aftermarket front and rear springs allowed. Minimum front spring height 9.5", minimum rear spring height 11".
9. Any aftermarket tubular upper A-arms are approved for use. Must be one-piece steel non-adjustable. Cross shaft must be steel only. Stock type ball joint only.
10. Shocks must be stock factory type. Pro, Bilstein & AFCO stock replacement shocks allowed; other brands must be approved. **Price limit is \$95.00 (list price) per shock.**
11. All steering components must remain stock. Stock drag links only.
12. Safety hub required on right-front wheel and encouraged for left-front. Right-front hub must be solid steel only.
13. Spindles must be stock Monte Carlo **or Impala** style. No **Camaro** or drop spindles.

14. Neoprene bushings are allowed.

15. BRAKES

1. Brakes on all four wheels must work at all times. Brakes will be checked.
2. Rear disc brakes allowed.
3. All brake parts must be OEM factory stock style. No racing style brake parts allowed.
4. S-10 or Toyota slave cylinder setup or one of the same allowed. No aftermarket.
5. Brake cooling ducts are allowed.

16. TIRES & WHEELS

1. Any stock steel wheel or racing wheel allowed. May be 14" or 15" diameter. **May be 7" or 8" width with any offset.**
2. DOT street tires only – **any size permitted.** No racing tires allowed. Stock tread only. No mud, snow, studded, directional, or recap tires allowed. No tire grooving allowed.
3. One-inch (1") lug nut mandatory on all studs. No exceptions.
4. Bead locks recommended on right-side tires.
5. Chemical treating of tires will not be allowed. No shaving of any tires allowed. A durometer rule will be in effect regarding minimum tire hardness. Durometer numbers will be determined and announced to competitors prior to first event.
6. Tire clean-up with scraper blades allowed. No form of any liquid allowed for cleaning tires.
7. Questionable tires, or tires not meeting above criteria as determined by officials, may be confiscated by officials and could result in disqualification and/or other penalties.

17. WINDOWS

1. All vehicles must have a full screen, Lexan or OEM glass windshield. No Plexiglas. Must be clear and supported by one upright brace in center, with minimum thickness of 1/8".
2. B-pillar window openings may be covered with clear Lexan only.
3. No rear windshields allowed.

18. WEIGHT

1. Management reserves the right to add or remove weight and/or change percentages on any car at any time in the interest of parity. **Each car will be required to add 25 lbs. after its second feature win, and each win thereafter; officials will dictate where the added weight will be located on each car.** Cars may be adjusted on an individual basis.
2. Weight measured with driver in seat, race-ready. Minimum total weight 3,000 pounds. No tolerance. Maximum rear weight percentage will be 48.0% for all cars.
3. All cars with non-sealed engines must add 100 lbs.
4. All added ballast must be made of lead – no other materials permitted.
5. Ballast must be painted white with car number highly visible on ballast in black.
6. Ballast must be 5 lbs. minimum, bolted securely to frame rails and in plain view. All ballast must be located above or between frame rails. No ballast may be hung beyond width of frame rails or below frame. No ballast may be mounted inside car.

IF QUESTIONS, CONTACT:

***John Cummings, Technical Inspector – (802) 265-3408 – Only 6 p.m. to 8 p.m.
Jeremy Carpenter, Technical Inspector – (518) 420-5445 – Text message preferred
Mike Bruno, Promoter/Race Director – (802) 236-9141 – Text message preferred***

***ALL RULES SUBJECT TO CHANGE WITH OR WITHOUT NOTICE. "EIRI" 6/14/19
Devil's Bowl Speedway © 2012-2019***

4-Point Roll Cage

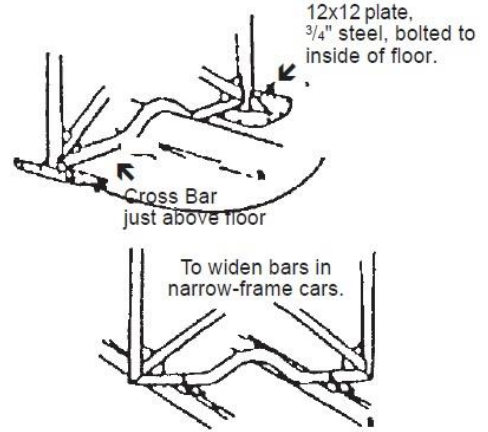
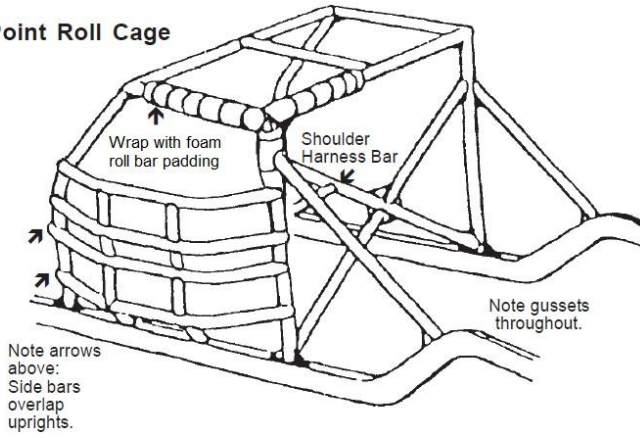

Recommended Seat Belt Installation

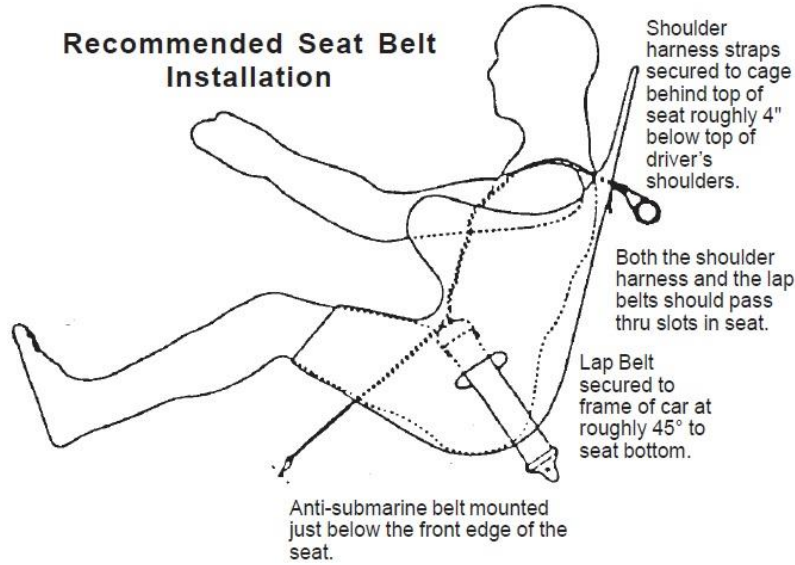

REV BOX WIRE DIAGRAM

