



2020

OFFICIAL RULES & REGULATIONS MINI STOCK

*NOTE: CHANGES FROM PREVIOUS YEAR **WRITTEN IN RED***

All cars **MUST** be equipped with a working RACEceiver-type one-way scanner and a working MYLAPS timing transponder.

RACEceiver website: www.raceceiver.com

MYLAPS website: www.mylaps.com

Devil's Bowl Speedway
Mailing Address: 261 Randbury Rd., Rutland, VT 05701
Physical/GPS Address: 2743 Route 22A, West Haven, VT 05743
Phone: (802) 265-3112 | Email: devilsbowlspeedway@gmail.com
Website: www.DevilsBowlSpeedwayVT.com

1. DIVISION SPECIFICATIONS

These rules have been developed as an attempt to keep the Mini Stock division affordable and at a hobby level. Contact management BEFORE making any modifications not listed here. **Drivers age 14-15 years old may apply for consideration to compete and will be evaluated on an individual basis.**

Safety is the biggest priority. All construction must meet Devil's Bowl Speedway specifications. No equipment will be considered as having been approved by reason of having passed through inspection unobserved. The technical inspector shall determine whether any type of construction, design, or interpretation of any rule shall be accepted.

Competitors should be aware that technical inspection for the Mini Stock division will continue to be thorough and rigorous in 2020. Please read carefully and adhere to all rules.

2. GENERAL RULES

1. The rules and/or regulations set forth herein are designed to provide for the orderly conduct or racing events and to establish minimum acceptable requirements for such events. These rules shall govern the condition of all events, and by participating in these events all participants are deemed to have obtained, read, understood, and complied with these rules. NO EXPRESSED OR IMPLIED WARRANTY OF SAFETY SHALL RESULT FROM PUBLICATION OF OR COMPLIANCE WITH THESE RULES AND/OR REGULATIONS; they are intended as a guide for the conduct of the sport and are in no way a guarantee against injury and/or death to a participant, spectator, or official. The interpretation and invoking of the rules published herein shall be determined by the officials at their professional discretion.
2. It is the responsibility of the competitor to obtain and become familiar with the current rules pertaining to the division in which he/she chooses to participate. The driver is as responsible as the owner, and it shall be the responsibility of both to know which parts are used in the race car that he/she owns and/or may be driving.
3. Any item not covered in these rules must remain stock or be approved in writing by Devil's Bowl Speedway. If any item being considered by a competitor is not addressed in these rules, the competitor is required to contact management for a judgment of its acceptability.
4. Technical Director and/or Track Manager will have final say on all rules, procedures, regulations, and/or technical authorities.
5. Safety is paramount. A driver must display the ability to control his or her car and be able to keep pace with the field in order to maintain their regular handicap. All rookie and/or novice drivers will be evaluated on a case-by case-basis. Any driver that cannot keep pace may be assigned a starting position at the rear until he or she can display enough control and speed to compete and maintain a regular handicapped position.
6. Management reserves the right to add and/or redistribute weight to any car at any time, and/or to adjust other rules governing any car to ensure a level playing field.
7. Devil's Bowl Speedway officials may claim any car (less safety equipment, roll cage, fuel cell, wheels, and tires) at any time for \$1,200. (Competitors may not claim cars or any other parts.) Drivers and/or car owners refusing to turn over claimed cars will be penalized, including but not limited to disqualification, monetary fine(s), and/or suspension.

3. SAFETY

1. All cars must have an aluminum racing seat (full containment seat recommended, no fiberglass allowed, factory stock seats not allowed) that must be fastened to roll cage, NOT bolted to the floorboard. Seat must have four (4) bolts in seat pan mounted to roll cage (not floor) and two (2) bolts on headrest/seatback area mounted to roll cage, using no less than 3/8" Grade 5 bolts. NO EXCEPTIONS.
2. Approved quick-release or cam lock racing seat belts required. Belts must be in good condition, recommended to be not more than three (3) years old. Stock passenger seat belts not permitted. Seat belts must be properly bolted (not welded) to roll cage (see diagram).
3. Approved driver window net mandatory - one-inch (1") webbing minimum. Must be mounted on 3/8" steel rod, top and bottom. Must be attached at top front and bottom front by quick-release or seat belt-type latching device. Net must be taut when latched.

4. Fully charged on-board fire extinguisher with working gauge required. Extinguisher must be mounted on crossbar on driver's right side with quick release (no taping), within reach of driver and accessible to safety crew from both left and right side windows.
5. Safety cut-off switch required on crossbar on driver's right side, within reach of driver and accessible to safety crew from both sides of car. **MUST BE CLEARLY LABELED.**
6. Battery must be mounted under hood in stock location, fully encased to prevent terminals from shorting out. Battery also allowed inside car – must be securely mounted in plastic marine-style battery box.
7. Rear-wheel drive driveshaft must be steel only and painted white. No aluminum driveshafts allowed. Two 360° driveshaft safety loops are required; must be constructed of at least 1/4" x 2" steel.
8. All roll bars within reach of driver must be padded with closed cell foam padding. Center of steering wheel must be padded.

4. ROLL CAGE

1. A roll cage is mandatory and must consist of four uprights joined together at all four corners of the top. Cage must be securely mounted with plates welded AND bolted to unibody or frame rails. Welds must be clean and uniform. (See diagram.)
2. All roll cage material must be minimum 1-3/4" diameter tubing with minimum .095" wall thickness. No square stock, angle iron, I-Beam, or any other material will be permitted. **NONE.** No splices in main cage.
3. The two rear uprights must be joined by an "X" brace, or by two horizontal bars and a diagonal bar.
4. Left side **MUST** have four (4) curved door bars with upright supports between bars. Right side must have three (3) curved door bars with supports between bars (recommended), or "X" style bars. Gussets highly recommended.
5. Horizontal bar required between the two front uprights at dashboard level.
6. Front and rear hoops allowed. Must remain within unibody/chassis structure. No external bars or rub rails.
7. Roll cage and/or other bars may not alter the geometry of the car.

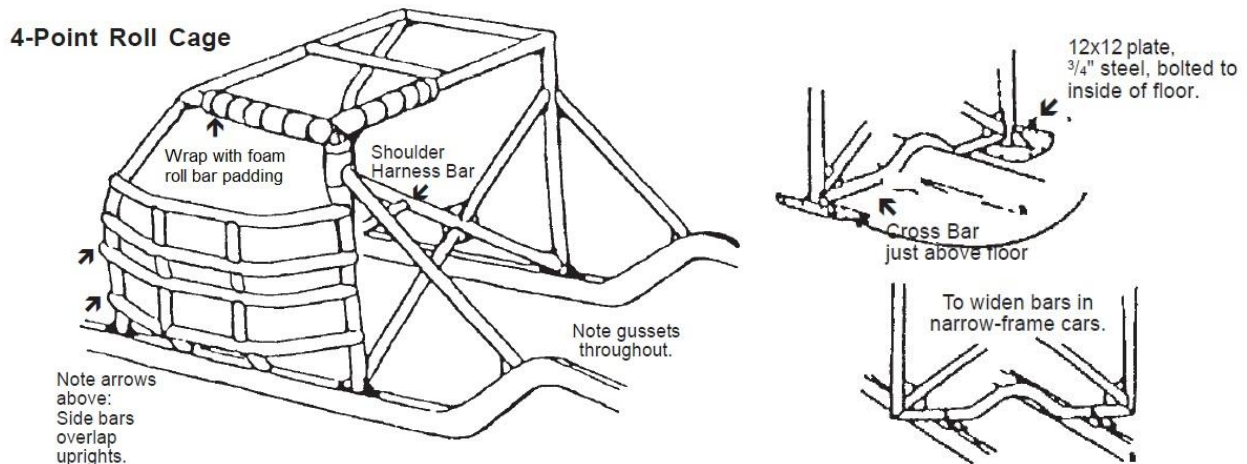

5. ELIGIBLE MODELS

1. For consideration of any vehicle not meeting the following guidelines, please **CONTACT OFFICIALS PRIOR TO BUILDING/PURCHASING VEHICLE.**
2. All teams must declare year, make, and model prior to competing. **DO NOT REMOVE** factory-issued Vehicle Identification Number (VIN) plate. VIN plate is required on all cars in 2020. (Exception: Vehicles without VIN plate that competed in 2019 may be grandfathered in; contact officials prior to competing.)

3. Open to any hardtop production vehicle with a 4-cylinder engine. Body style may include 2-door, 4-door, hatchback, or station wagon. No convertibles or T-tops. Sunroofs must be covered with sheet metal.
4. No Subaru allowed.
5. Honda/Acura VTEC engines will be permitted in 2020 but will be examined in competition during the season and may not be permitted in the future. Contact officials with questions.
6. Eligible model years up to and including 2010; contact officials concerning other years.
7. Minimum wheelbase 96", maximum wheelbase 104.5". Both sides must be same length.
8. All-wheel drive cars must be converted to front-wheel drive by removing rear driveshaft.
9. Compact pickup trucks with 4-cylinder engines allowed. CONTACT OFFICIALS PRIOR TO BUILDING. (Examples: Chevrolet S-10, Ford Ranger, Mazda B-Series, Nissan Hardbody, etc.)

6. WEIGHT

1. Management reserves the right to add or remove weight and/or change percentages on any car at any time in the interest of parity. Each car will be required to add 25 lbs. after its second feature win, and each win thereafter; officials will dictate where the added weight will be located on each car. Cars may be adjusted on an individual basis.
2. Starting weights will be as follows and may be adjusted in the interest of parity:

<u>Engine/Car Type</u>	<u>Minimum Total</u>	<u>Maximum Left Side</u>
Single Cam	2,200 lbs.	55%
Dual Cam	2,400 lbs.	55%
Honda VTEC Single Cam	2,400 lbs.	51%
Honda VTEC Dual Cam	2,600 lbs.	51%
Ford Focus SVT	2,600 lbs.	51%

3. All added ballast must be made of lead – no other materials permitted.
4. Ballast must be painted white with car number highly visible in black. Ballast must be 5 lbs. minimum, bolted securely to unibody/frame rails and in plain view. All ballast must be located ahead of centerline of rear axle and above or inside unibody/frame rails. No ballast may be hung under floor.
5. Teams advised to read this rulebook carefully to see where other weight may be required.

7. CAR, BODY, & INTERIOR SPECIFICATIONS

1. Remove all glass, lights, and trim. Windshield must be removed and replaced with ½" wire mesh screen. No glass, Lexan, or Plexiglas allowed. Must have two (2) one-inch (1") upright supports, equally spaced.
2. Rear windshield and door windows must be kept open and clear. No glass, Lexan, Plexiglas, screen, metal, or any other material may cover window openings. **Rear quarter windows must be kept open – no screen or Lexan allowed.**
3. All cars must have full body. No "Mini-Modified" bodies allowed. Body panels must remain stock or stock-appearing for year, make, and model. Inner tin may be removed from trunk lids, hoods, and inside of door panels. Doors and lower section of rear quarter panels may be replaced with aftermarket or steel panels but must retain stock appearance.
4. All doors must be welded, bolted, or chained shut.
5. Bumper and/or bumper cover must maintain stock appearance. Bumper may be reinforced but must be securely attached to chassis. Replacement aftermarket racing-type plastic nose and tail only allowed with PRIOR approval.
6. External rub rails allowed. Must be a single bar only, maximum 1-1/2" round tubing, and must not extend more than two inches (2") past the door on either side. Must be mounted flush with the body and must use quick release pins inside door. Ends must be rounded and/or turned in toward body. (NOTE: Rub rails are intended ONLY to keep body repairs to a minimum and NOT to be used as a battering ram. Any driver deemed to be using rub rails to "move" other cars will be directed to remove rub rails for a minimum of one event. DO NOT abuse this privilege!)
7. All stock seats, interior upholstery, fabric, plastic, and chrome must be removed.
8. No mirrors allowed.

9. All holes in floor and front and rear firewalls must be covered with tin or steel.
10. Dashboard must remain stock or may be replaced with aluminum.
11. All sunroof and/or T-top assembly must be removed and covered with steel.
12. Hood and trunk latches must be removed. Minimum two (2) pins each in hood and trunk. No Dzus-type fasteners allowed on hood and trunk.
13. Must have at least one (1) tow hook on both front and rear of car.
14. All cars must have a working MYLAPS-brand transponder mounted inside car on right-side floorboard. Transponder must be securely fastened, mounted vertically with sensor pointing down to race track. Centerline of transponder must be located 13 feet (156") from the leading edge of the front of the car. Drivers are responsible to ensure that transponder has a valid, active subscription and that battery is fully charged. Any car without a working transponder is subject to being omitted from finish order. *(The MYLAPS "X2" transponder is highly recommended. Visit www.MYLAPS.com for more information.)*

8. ENGINE

1. Mini Stock engines will be closely inspected in 2020. Be prepared to remove any engine part – or entire engine – at any time.
2. Engine and all related components including but not limited to mechanical, electrical, and computer must be FACTORY STOCK for year, make, model, and trim package. Must have stock block, cylinder head, valves, intake, carburetor or fuel injection, exhaust, ignition, pistons, rods, and crankshaft for year, make, and model. No mixing and matching of parts, including within sub-models and trim packages.
3. Any computer may be claimed at any time by Devil's Bowl Speedway officials. (Competitors may not claim computers or any other parts.) All claimed computers will be tested; if computer is found to be modified from factory stock setting, driver and/or car owner will be penalized, including but not limited to disqualification, fines, and/or suspension. Drivers and/or car owners refusing to turn over claimed computers will be penalized, including but not limited to disqualification, fines, and/or suspension.
4. The following models will be permitted but may be subject to rule adjustments: Mopar Shelby, GLH, R/T, and SRT; Ford Shelby, SVO, and SVT; Honda VTEC; any Toyota. CONTACT OFFICIALS PRIOR TO BUILDING/PURCHASING VEHICLE.
5. All cars MUST have lettering on each side of the hood area declaring engine size and type. Letters/numbers must be a minimum of three inches (3") high. (See diagram.)
6. Four-cylinder engines only. Single cam, single overhead cam (SOHC), or dual overhead cam (DOHC) engines allowed. No turbochargers or superchargers. No rotary engines.
7. Single-cam engines may use any camshaft. DOHC engines must run factory stock camshafts for year, make, and model.
8. Engine must maintain stock compression and compression ratio.
9. Resurfaced cylinder heads and/or engine blocks must be shimmed to retain stock tolerance. (Example: If .010" planed from head, .010" shim must be used.)
10. Maximum block overbore .030" for cleanup only – NO TOLERANCE.
11. Exhaust manifold must remain stock. Exhaust must dump behind driver under car. No holes in firewall. Pipe must remain stock width to match year, make, and model throughout, absolute maximum 2.5" in diameter. Muffler and catalytic converter may be removed, though muffler may be required to meet 95 decibel limit.
12. Aftermarket air filter allowed. Filter must be in factory stock configuration and location, including stock air box or housing assembly. No holes in hood, no headlight mounts. No air deflectors, ram air, cowls, sheet metal, hoses, tubes, inductors, or other add-ons allowed.
13. No antifreeze permitted. Other additives must be approved prior to use.
14. Aftermarket coil packs are allowed in the Mini Stock class, so long as they are stock or stock equivalent replacement parts with no clear performance advantage.
15. Traction control devices of any kind are not allowed. Factory systems must be disabled.
16. FORD MUSTANG ONLY:
 - a. Cylinder head may be planed up to a maximum of .100" from stock thickness.
 - b. May use any cam or rockers.

- c. Must use stock valves – 1.735” diameter.
- d. May use 350 cfm carburetor. Must be stock except for optional choke plate removal.
- e. May use maximum 110 octane fuel.
- f. May use exhaust header – Speedway Motors Part #91013239 ONLY.
- g. May use any flywheel – minimum weight 12 lbs.

9. TRANSMISSION & DRIVELINE

1. Transmission must be FACTORY STOCK for year, make, and model. All components must remain stock. Automatic or manual allowed. No Mopar SRT Turbo transmissions allowed.
2. Flywheel, clutch, rear end, driveshaft, and all other driveline components must remain factory stock for year, make, and model.
3. Limited slip differential not allowed in any vehicle.
4. Rear-wheel-drive may be welded.

10. SUSPENSION & BRAKES

1. Minimum ground clearance 4.5” at lowest point, including cross members and body panels.
2. Any wheel camber permitted, except on Honda VTEC – maximum one degree (1°).
3. Coil springs must be stock or stock appearing – price limit \$65.00 (list price) per spring. Stock springs may be cut. Spring rubbers must be securely fastened.
4. No coilover shocks or struts. No adjustable shocks or struts. No leaf springs.
5. Shocks and struts must remain in stock location and configuration, front and rear – may be reinforced. Cars with front struts moved and/or mounted to front roll bar hoop must add 100 pounds. Teams are strongly advised to not build any new cars with moved struts.
6. No rear steering allowed.
7. Brakes on all four wheels must work at all times. Anti-lock brake systems must be disabled.
8. Safety hubs allowed.

11. FUELING SYSTEM

1. Unleaded pump gas only – maximum 94 octane. NO RACING FUEL, additives, other fuels, or mixes allowed whatsoever. Violators will be disqualified – *don't push it!*
2. Fuel cell with foam and bladder highly recommended, 8 gallon maximum, securely mounted in trunk. Stock fuel tank permitted only if located in front of rear axle. Fuel cell or tank must be secured by a minimum of two (2) one-inch (1”) metal straps.
3. Fuel pumps must be stock with stock pressure and must turn off with ignition switch.
4. Fuel lines must be metal, mounted inside car out of driver's reach. No glass or plastic filters.
5. NO LEAKS!

12. TIRES & WHEELS

1. Any DOT radial tire allowed. Minimum 360 treadwear. Must be 55 Series or higher. List price limit \$75.00 per tire. No directional tires allowed. All-Season “M&S” rated tires are allowed.

No all-terrain, mud, or snow tires, no snowflakes. Tires with this symbol  are not permitted.

2. Minimum air pressure allowed in RIGHT FRONT tire:
 - Front-wheel drive – 30 psi
 - Rear-wheel drive – 25 psi
3. One-inch (1”) lug nut mandatory on all studs with 45° bevel lug nuts – NO EXCEPTIONS.
4. Any factory stock steel, aluminum, or alloy wheel permitted in 14”, 15”, or 16” diameter only. Maximum width 7”. All four wheels must be matching diameter, width, and offset.
5. Aftermarket racing wheels allowed and recommended – 7” WIDTH ONLY. All four wheels must be matching diameter, width, and offset. Offset must be 3” minimum.

Recommended Dealer: Bassett Racing Wheels – 1 (888) 888-7199 – www.bassettwheel.com

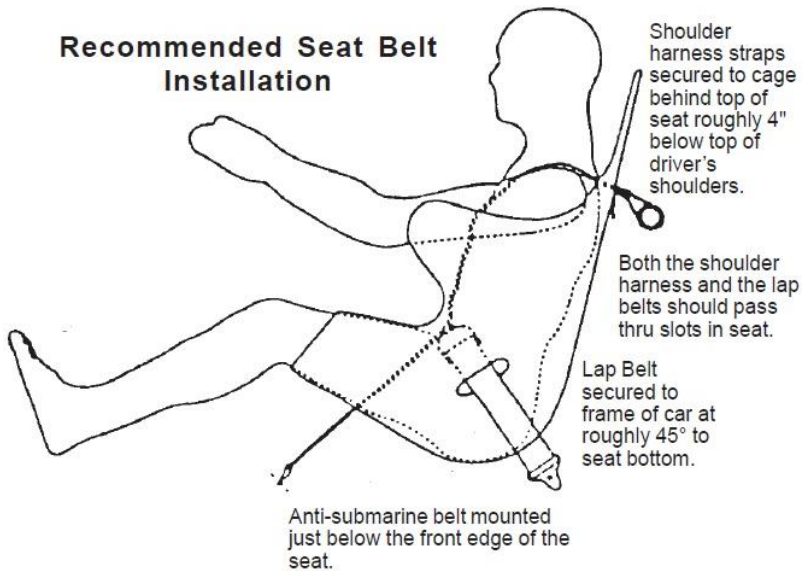

**MANDATORY
MINI STOCK ENGINE SIZE
HOOD DECAL EXAMPLE**

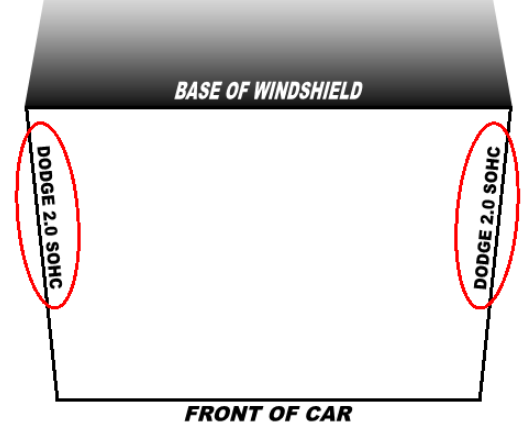

TIRES WITH THIS SYMBOL ARE NOT ALLOWED:



***IF QUESTIONS, CONTACT:
Jeremy Carpenter, Technical Inspector
(518) 420-5445 - Text Message Preferred***

Mike Bruno - (802) 236-9141

***ALL RULES SUBJECT TO CHANGE WITH OR WITHOUT NOTICE. "EIRI" 1/28/20
Devil's Bowl Speedway © 2012-2020***