



2021

OFFICIAL RULES & REGULATIONS SUPER STOCK

*NOTE: CHANGES FROM PREVIOUS YEAR **WRITTEN IN RED***

All cars **MUST** be equipped with a working RACEceiver-type one-way scanner and a working MYLAPS timing transponder.

RACEceiver website: www.raceceiver.com

MYLAPS website: www.mylaps.com

Devil's Bowl Speedway
Mailing Address: 261 Randbury Rd., Rutland, VT 05701
Physical/GPS Address: 2743 Route 22A, West Haven, VT 05743
Phone: (802) 265-3112 | Email: devilsbowlspeedway@gmail.com
Website: www.DevilsBowlSpeedwayVT.com

1. SUPER STOCK SPECIFICATIONS

The Super Stock division is meant to provide an enjoyable class of auto racing on a “hobby” level. Drivers age 14-15 years old must apply for consideration to compete and will be evaluated on an individual basis.

Please read these rules carefully, as there are many changes for the 2021 season. This rulebook has been developed by several speedways in the region so that teams may compete at a variety of tracks without making major changes to their cars.

Be advised that in the interest of parity, some changes may be made to individual cars based on performance – particularly with cars that dominate competition on a regular basis.

Because of the many types of automobiles that may be built using these rules, it is improbable for these rules to detail every situation that might occur. Accordingly, management is given discretion to rule on any matter not covered specifically in these guidelines. Devil’s Bowl Speedway reserves the right to make changes in these rules at any time, with or without notice, should changes become necessary to ensure greater safety or more equal competition.

2. GENERAL RULES

1. The rules and/or regulations set forth herein are designed to provide for the orderly conduct of racing events and to establish minimum acceptable requirements for such events. These rules shall govern the condition of all events, and by participating in these events all participants are deemed to have obtained, read, understood, and complied with these rules. NO EXPRESSED OR IMPLIED WARRANTY OF SAFETY SHALL RESULT FROM PUBLICATION OF OR COMPLIANCE WITH THESE RULES AND/OR REGULATIONS; they are intended as a guide for the conduct of the sport and are in no way a guarantee against injury and/or death to a participant, spectator, or official. The interpretation and invoking of the rules published herein shall be determined by the officials at their professional discretion.
2. It is the responsibility of the competitor to obtain and become familiar with the current rules pertaining to the division in which he/she chooses to participate, **as well as the additional “Official Rules & Regulations” rulebook for all divisions and participants.** The driver is as responsible as the owner, and it shall be the responsibility of both to know which parts are used in the race car that he/she owns and/or may be driving.
3. Any item not covered in these rules must remain stock or be approved in writing by Devil’s Bowl Speedway. If any item being considered by a competitor is not addressed in these rules, the competitor is required to contact management for a judgment of its acceptability.
4. Technical Director and/or Track Manager will have final say on all rules, procedures, regulations, and/or technical authorities.
5. Safety is paramount. A driver must display the ability to control his or her car and be able to keep pace with the field in order to maintain their regular handicap. All rookie and/or novice drivers will be evaluated on a case-by case-basis. Any driver that cannot keep pace with the field may be assigned a starting position at the rear of the field until he or she can display enough control and speed to compete and maintain a regular handicapped position.
6. Management reserves the right to add weight and/or change percentages to any car at any time, and/or to adjust other rules governing any car to ensure a level playing field.

3. CHASSIS SPECIFICATIONS

1. Any OEM stock American-made sedan permitted, 1955 to present.
2. No front-wheel drive, 4-wheel drive, or rear-engine chassis.
3. OEM wheelbase maximum 108.1” for full frame cars, maximum 110” for unibody cars. Contact officials with questions concerning other vehicles.
4. The only pre-approved racing-style tube chassis is the Johnson Chassis “XYG” GM Metric copy. Other racing/tube chassis must receive prior “grandfather” approval from officials, including those that competed in 2020 or prior years.
5. Complete bumper-to-bumper steel unibody must be retained on unibody cars. Rear frame may be plated as long as stock configuration is maintained, or replaced with 2” x 3” (only) square tubing from center of rear rearward.

6. Frames may be "X" braced. Unibodies must be tied – rear frame to front frame.
7. Engine may be mounted so that the #1 spark plug is in line with the center of the ball joint, or any point forward.
8. All cars must have a working MYLAPS-brand transponder mounted on right-side of right-rear frame rail. Transponder must be securely fastened, mounted vertically with sensor pointing down to race track. Centerline of transponder must be located 12" behind the rear edge of the rear axle tube, not more than 12" high from the ground. Any car without a working transponder is subject to being omitted from finish order. (The MYLAPS "X2" transponder is highly recommended. Visit www.MYLAPS.com for more information.)

4. BODY & INTERIOR SPECIFICATIONS

1. Cars must be neat appearing – all sharp edges and torn panels must be repaired and painted.
2. Any OEM stock American-made sedan, wagon, or truck body permitted, 1955 to present. Sunroof or T-tops must be reinforced and enclosed. No convertibles.
3. OEM stock bodies must appear stock and must use roof, hood, decklid, front fenders, and rear quarterpanels as manufactured. Inner tin may be removed. Wheel wells may be trimmed within reason for tire clearance.
4. Doors may be replaced with sheet metal. Fenders and quarters may be replaced with sheet metal if stock appearance is maintained. No other homebuilt bodies or panels.
5. Fiberglass roof allowed. Nose and tail may be replaced with plastic aftermarket racing parts.
6. No dirt Late Model or wedge-style bodies. No dirt Modified body parts.
7. The only aftermarket body packages allowed are as follows and must be used in their entirety with no alterations. No ABC or S2 bodies. Other aftermarket bodies must receive approval.

<i>Body Manufacturer</i>	<i>Year/Model</i>
AR Bodies	2012 (Street Stock) Camaro/Challenger/Mustang
AR Bodies	2012 Silverado
Five Star	1988 Monte Carlo
Five Star	2002 or 2018 (Short Track Truck) Silverado/F-150
Performance Bodies	1981 Camaro
Performance Bodies	1988 Monte Carlo

8. Stock hood and trunk latches must be removed with quick-release pins installed – minimum three in front of hood and two in rear of trunk. Handle on front of hood recommended for fire/safety crew. **No Dzus-type fasteners allowed – this is not a new rule!**
9. Stock firewall may be removed but must be replaced with tin.
10. Tin replacement dashboard must be in stock location.
11. All stock glass, seats, plastic, upholstery, lights, trim, and chrome must be removed.
12. No mirrors allowed.
13. Doors must be secured shut (welded, chained, bolted, etc.).
14. No holes in hood. No ram air induction.
15. Door skirts allowed. A 4" minimum clearance must be maintained. This rule is absolute.
16. Rear spoiler maximum width 60" (including side enclosures), maximum spoiler blade material height 4". No lips, bends, or fins in middle of spoiler. Spoiler must be non-adjustable, mounted flush to surface of deck lid or tailpiece. Side enclosures maximum 6" long and 4" high, mounted 90° perpendicular to spoiler blade and 90° perpendicular to deck lid. All material must be minimum .090" thickness aluminum or Lexan (no Plexiglas).
17. Bumpers must be securely fastened to chassis to withstand impact. Bumper ends may not be braced. Tow hook highly recommended, front and rear, using minimum 5/16" chain.
18. Cars without rear bumper covers must have full tin enclosure surrounding fuel cell.
19. Interior tin may be added for "cockpitting." Tin in center of vehicle must be no higher than driveshaft tunnel. Tin may extend in a single plane, to be no higher on right side than bottom of window opening. All work must be neat with no sharp edges and must not impede driver's escape routes. Technical inspectors have sole discretion – contact officials with questions.

5. ROLL CAGE

1. Four-point cage required with door protection bars. Must be securely welded to frame. Roll cages will be inspected. See construction diagram at the back of this rulebook.
2. Roll cage must be made of 1-3/4" dia. x .095" wall round steel tubing, or 1-1/2" dia. x .120" wall round steel tubing. Absolutely no square tubing or galvanized pipe allowed.
3. Rear main hoop of roll cage must be no closer than 28 inches (28") from center of rear axle to back part of the upright on back part of the cage. Cars not in compliance must add 50 lbs., located forward of the centerline of the wheelbase. Cars that competed in 2020 *may* receive a "grandfather" clause – please contact officials prior to competition.
4. Horizontal bar required behind driver's seat to prevent seat from collapsing backward. Support for headrest and/or seatback extending up to support back of head is mandatory.
5. Minimum roll cage clearance 3" from driver's head.
6. Single front hoop within confines of body, no wider than stock frame rails may be attached to main roll cage/chassis. Must be parallel to frame and have a maximum of four (4) uprights.
7. No internal reinforcement of bumpers allowed.
8. Fuel tank protection bar mandatory, mounted frame rail to frame rail, no higher than the fuel cell and inside trunk area. Bottom of fuel cell must be no lower than bottom frame rail.

6. SAFETY

1. All cars must have an aluminum racing seat (full containment seat recommended, no fiberglass allowed) that must be fastened to roll cage/chassis, NOT to floorboard. Seat must have four (4) bolts in seat pan mounted to roll cage and two (2) bolts on headrest/seatback area mounted to roll cage, using no less than 3/8" Grade 5 bolts. NO EXCEPTIONS.
2. Approved quick-release or cam lock racing seat belts required. Belts must be in good condition, not more than three (3) years old. Stock passenger seat belts not permitted. Seat belts must be properly bolted (not welded) to roll cage (see diagram).
3. ***Beginning in 2021 season, approved head-and-neck restraint system is mandatory for all Super Stock drivers age 17 and under, and is highly recommended for all drivers.***
4. Approved driver window net mandatory. Must be in good condition, not more than three (3) years old. Must be mounted on 3/8" steel rod, top and bottom. Must be attached at top-front and bottom-front by quick-release or seat belt-type latch. Net must be taut when latched.
5. Fully charged fire extinguisher with working gauge highly recommended. Extinguisher must be mounted on driver's right side with quick release (no taping, no plastic brackets), within reach of driver and accessible to safety crew from both left and right-side windows.
6. Safety cut-off switch required on crossbar on driver's right side, within reach of driver and accessible to safety crew from both left and right-side windows.
7. Battery must be under hood or behind driver's seat and fully encased to prevent shorting.
8. Fuel cell mandatory, mounted in trunk, 22-gallon maximum. In stock frame cars, fuel cell must be mounted in trunk above frame rails. In tube frame cars, fuel cell must be horizontally centered between frame rails, enclosed in 20-gauge steel container; minimum height 12" from ground to bottom of steel container.
9. No plastic fuel filters allowed.
10. Driveshaft must be steel only and painted white. No aluminum driveshafts allowed.
11. One 360° driveshaft loop is required. Must be constructed of at least 1/4" x 2" steel.
12. ***Driver required to have one-way radio (RACEceiver or similar) for contact with Race Control. Radio must be working and active prior to any on-track activity. Two-way radios, cell phones, Bluetooth, other audio or digital devices, and/or any other means of communication other than the required one-way Race Control radio not permitted.***

7. ENGINE

1. All teams are required to complete and submit an official Engine Registration Form prior to competition. It is the responsibility of the driver and/or car owner to report any subsequent engine changes prior to competition. It is also the responsibility of the driver and/or car owner to report any engines or seals not already approved prior to competing.

2. Cars with unsealed crate engines, or rebuilt crate engines (example: RPM, Hunt's, DMO, etc.) must add 100 lbs. and may be subject to other penalties including additional weight.
3. Teams must be prepared to remove engine at any time to be inspected and/or dynamometer checked at an independent site designated by Devil's Bowl Speedway. Refusal to do so will result in disqualification and/or additional penalties.
4. **OPTION #1 – GENERAL MOTORS "602" CRATE ENGINE**
 - a. The only crate engine approved for use in the Super Stock division is the General Motors "602" crate engine (Part #88958602 or #19258602). Crate engine must meet all factory GM specs and have approved factory GM seals and/or bolts.
 - b. **Rebuilt and/or repaired crate engines must be within GM specifications and cars must add 150 lbs. Teams must declare engine type on registration forms and report in detail any work performed. Additional work must receive prior approval from Devil's Bowl Speedway officials. Violators will be penalized.**
 - c. OEM factory stock valve springs only – GM replacement Part #19154761.
 - d. Any parts not listed in these rules must be factory stock.
 - e. **PENALTIES:** Violation of these rules will result in the following penalties:
 1. Failure to report engine or part change prior to competition – Minimum penalty: Disqualification from event; \$500 fine; driver and/or owner suspended until paid.
 2. Tampering with engine, fuel, or seals – Minimum penalties: Disqualification from event; \$1,000 fine; driver and/or car owner will lose all points accumulated in current season; driver and/or car owner will be suspended for one calendar year or until fine is paid, whichever comes last.
 3. Second offense: Driver and/or car owner suspended minimum one calendar year and fined \$2,000. Multi-time violators may be suspended indefinitely.
5. **OPTION #2 – "BUILT" ENGINE**
 - a. Weights may be adjusted in the interest of parity.
 - b. Maximum cubic inch limit is 360 for all cars. Engine must remain stock for vehicle. (Exception: Chevrolet 350 CID engine may replace any other Chevrolet V8.)
 - c. No removal or alterations to casting numbers allowed on any engine part.
 - d. All engines are allowed .040" overbore for clean-up and/or wear.
 - e. **CRANKSHAFT**
 1. No lightening holes, O.D., trimming, or any other lightening features. Oil holes may be chamfered.
 2. Main bearing diameter 2.448.
 3. Crankshaft must be stock for engine.
 4. Connecting rod journal diameter 2.100.
 5. Minimum weight 48 lbs.
 6. Throws and counterweights must not be narrowed or knife-edged. No center cutting on counterweights. No holes through crank pins.
 7. Machined steel crank pulley allowed. No aluminum.
 - f. **PISTONS**
 1. Flat-top pistons allowed. Domed pistons NOT allowed.
 2. Cast pistons must be Full Skirt, matching four eyebrows and three rings in stock location.
 3. Chevrolet must use stock OEM cast or cast replacement pistons.
 - g. **RODS**
 1. Stock OEM connecting rods must be used. No modifications allowed.
 2. Aftermarket rod bolts allowed. Must be 5.7 length.
 - h. **CYLINDER HEADS**
 1. Stock OEM iron heads allowed.
 2. Double humped heads allowed.
 3. No guide plates allowed.
 4. No Vortec, Bow Tie, Dart, Brodix, etc., allowed.
 5. No aluminum heads allowed.
 6. No angle plug heads allowed.

7. No angle milling allowed. No more than 3 cc's can be flat machined or ground from gasket surface of cylinder heads. Factory cc specs will be used as guidelines.
8. Valve stem diameter to .343" +/- .005". Intake valve head diameter not to exceed 1.940". Exhaust valve diameter not to exceed 1.500".
9. Screw-in studs allowed. No poly locks.

i. CAMSHAFT

1. Hydraulic cams and lifters only. No roller cams or lifters.
2. Camshaft lift may be measured at the valve rocker arm. Maximum valve lift will be as follows:

<u>Engine</u>	<u>Intake</u>	<u>Exhaust</u>
Buick	.402	.418
Chevrolet	.390	.410
Chrysler	.429	.444
Ford Cleveland	.461	.463
Ford Windsor	.427	.465
Oldsmobile	.450	.450
Pontiac	.400	.410

j. ROCKER ARMS

1. Stock rockers and ratio (1.5) must be maintained. Long slot rockers allowed.
2. Chevrolet rockers must have triangular insignia.
3. No guide plates.

k. INTAKE MANIFOLD

1. Stock cast iron two-barrel intake for year, make, and model. No aluminum.
2. Maximum thickness of gaskets and spacer (if used) must not exceed a total of ¼", measured from the base of the carburetor to the top of the intake manifold.

l. FUEL PUMP

1. Holley or Carter fuel pumps allowed.
2. No electric fuel pumps.

m. OILING SYSTEM

1. No racing oil pans.
2. 1" diameter inspection plug mandatory.

8. CARBURETOR

1. Two-barrel carburetors only. Maximum \$850.00 (list price) for carburetors.
2. No Demon carburetors allowed. No Holley Ultra HP or similar carburetors allowed.
3. Holley 4412: Venturi size 1-3/8" and a maximum throttle bore of 1-11/16". No polishing anywhere that air flows. Choke horn cannot be removed. Venturi area must not be altered in any way. Stock butterflies only. Idle holes may be drilled out to .125". Throttle shaft must remain stock and may not be thinned in any way. A maximum 1-1/8" spacer height including gaskets between carburetor and intake. Must have two return springs on throttle.
4. Carburetor spacer plate on all engines and carburetors must be one-inch (1") maximum thickness with no alterations whatsoever. No tapered spacers. **No ported carburetor adapters.** No Super Suckers or similar.
5. No holes in hood. No ram air induction. Hood and air cleaner must be separate. **No cold air boxes allowed.**
6. Five Star cold air boxes allowed, must be in stock configuration from factory. No additional air deflectors, cowls, sheet metal, hoses, tubes, inductors, or other add-ons allowed.

9. FUEL

1. Maximum octane 98 fuel. No additives or other fuels permitted. No Crate Extreme or other high-dollar fuels permitted.
2. Holley or Carter fuel pumps allowed. No electric fuel pumps.

10. EXHAUST

1. Stock OEM cast iron manifolds only. No grinding, polishing, porting, acid porting, or any other alterations permitted.
2. The only headers allowed are Schoenfeld parts #185MCM2 and #135CM2 (crossover). No homebuilt headers permitted.
3. Complete exhaust system must remain under car and exit to rear behind driver's seat. No center dump type manifolds. Must remain dual exhaust, no crossover or "Y" pipes allowed.
4. Maximum exhaust pipe diameter is 3".
5. Primary pipes must maintain a 1-5/8" diameter from flange to collector. Maximum header flange or adapter flange thickness is 3/8".
6. Mufflers are recommended. Only stock or "California Turbo" mufflers will be allowed. The use of round glass pack type mufflers is allowed. Mufflers may not be altered or modified from original design in any way.
7. Tri-Y, 180° headers, step headers, stainless steel, coated, ceramic and/or otherwise, and/or merge collectors not permitted. No powder coated or exotic type headers.
8. No exhaust pieces may be welded. All pieces must be removable and able to be inspected.

11. IGNITION

1. Stock HEI ignition coil only. No dual point ignition. Must remain stock from GM.
2. All 602 crate engines are strongly recommended to use MSD Part # 8727CT Ignition Box limited to 6,000 rpm – box must be operational at all times.
3. Rev box and coil must be mounted in engine compartment, under hood, out of reach of driver. Ground wire must be mounted to back of intake manifold. When hood is removed, rev box and all wires must be uncovered and clearly visible. (See diagram.)
4. GM factory distributor ONLY – Part # 93440806. The ONLY modification allowed is the removal of the vacuum adjustment.
5. The distributor advance curve and/or all parts must remain stock as manufactured.
6. **NO TRACTION CONTROL DEVICES OF ANY KIND ALLOWED. All electronic and/or computerized wheel spin and/or ignition retardation and/or acceleration limiting and/or traction control devices of any type not permitted. Adjustable ping control devices, dial-a-chip controls, timing controls and/or automated throttle controls not permitted. Remote control components of any type not permitted.**

12. COOLING SYSTEM

1. Any stock passenger car type radiator. Aluminum radiator allowed.
2. Conventional and electric fans are allowed.

13. TRANSMISSION

1. Only steel parts allowed in clutch and driveline. No aluminum, magnesium, titanium, or other materials.
2. Steel scatter-proof 360° bellhousing required. Minimum 1-3/4" (2" maximum) inspection hole mandatory, drilled in bottom of bellhousing.
3. All gears must be in working order.
4. Transmission cross member not required, however rubber or solid mount for transmission is required.
5. AUTOMATIC:
 - a. Stock three-speed, must remain OEM stock – Turbo 350 and C4 only. No Turbo 400, C6, 727, or any other model. No Powerglides. No two-speed, four-speed, or special racing automatics.
 - b. Stock 12" torque converter only.
6. MANUAL:
 - a. Stock three-speed only. Standard stock clutch (10.4") and flywheel assembly only.
 - b. One clutch, one diaphragm-type pressure plate only. No lightening of pressure plate. No aluminum pressure plates allowed – must be completely steel.

- c. Flywheel must be steel only and weigh minimum 15 lbs. with bolts. GM "602" crate engine must use GM flywheel Part #14088646 (15 lbs.) or GM flywheel Part #14088650 (25 lbs.).
- d. Hydraulic throw-out bearings allowed.

14. REAR END

1. Stock only. GM limited slip, welded rears, spools, and floaters allowed. No Detroit lockers.
2. No truck rear ends allowed.
3. Trailing arms must be OEM stock, or stock length radius rods with heim joints. Must be one-piece, non-adjustable steel. Aftermarket trailing arms or radius rods must maintain stock shape, size, length, configuration, and dimensions as manufactured. No bends by either the manufacturer or by modification will be allowed. Left and right sides must be the same style – no mixing and matching.
4. Rear end and all mounts must be in OEM stock location without adjustability. **All stock and aftermarket upper and lower rear control arms must be non-adjustable.**
5. Nine-inch (9") Ford rear allowed. (Five-bolt pattern only.)

15. SUSPENSION

1. Maximum tread width 68.5" for all cars – no tolerance. Measured from outer bead of wheels.
2. Minimum frame height is 6" with driver in seat, race ready.
3. Adjustable jacking bolts are approved for all cars on all four springs. Adjustable spring cups allowed. Spring spacers (including spring rubbers) allowed. No lumber or chains allowed.
4. A maximum 1-1/4" front anti-roll (sway) bar is allowed in any location. Use of threaded rod to connect sway bar to A-arms is permitted. No rear sway bars. **No free-floating sway bars. Stock size sway bars only.**
5. Rear suspension must be 4-link system. No 3-link systems allowed.
6. Rear leaf springs are allowed. Must be mounted in shackles, not sliders.
7. Regular "big spring" coil springs only. No coilovers.
8. All coil springs must be stock appearing and mounted in stock factory position. Springs may be cut. Aftermarket front and rear springs allowed. Minimum front spring height 9.5", minimum rear spring height 11".
9. Any aftermarket tubular upper A-arms are approved for use. Must be one-piece steel non-adjustable. Cross shaft must be steel only. Stock-type ball joint only.
10. Shocks must be stock factory type, **mounted in stock location.** Pro, Bilstein & AFCO stock replacement shocks allowed, but cannot be adjustable or rebuildable; other brands must be approved. Price limit \$100.00 per shock.
11. All steering components must remain stock. Stock drag links only.
12. Safety hub required on right-front wheel and encouraged for left-front. Right-front hub must be solid steel only.
13. Spindles must be stock Monte Carlo or Impala style. No Camaro or drop spindles.
14. Neoprene bushings are allowed.

16. BRAKES

1. Brakes on all four wheels must work at all times. Brakes will be checked.
2. Rear disc brakes allowed.
3. All brake parts must be OEM factory stock style. No racing style brake parts allowed.
4. Aftermarket master cylinders and pedals are allowed.
5. Brake cooling ducts are allowed.

17. TIRES & WHEELS

1. Any stock steel wheel or racing wheel allowed. May be 14" or 15" diameter. May be 7" or 8" width with any offset – wheel width tolerance will be 1/4" maximum, so long as total tread width does not exceed 68.5". All four wheels must be the same size.

2. DOT street tires only – any size permitted. No racing tires allowed. Stock tread only. No mud, snow, studded, directional, or recap tires allowed. No tire grooving or siping allowed.
3. One-inch (1”) lug nut mandatory on all studs. No exceptions.
4. Bead locks recommended on right-side tires.
5. Chemical treating of tires will not be allowed. No shaving of any tires allowed. A durometer rule will be in effect regarding minimum tire hardness. Durometer numbers will be determined and announced to competitors prior to first event.
6. Tire clean-up with scraper blades allowed. No form of any liquid allowed for cleaning tires.
7. Questionable tires, or tires not meeting above criteria as determined by officials, may be confiscated by officials and could result in disqualification and/or other penalties.

18. WINDOWS

1. Windshield must be 1/2” square heavy-duty steel wire screen. Must be supported by two vertical braces, minimum thickness of 1/8”.
2. B-pillar window openings may be covered with clear Lexan only.
3. No rear windshields allowed.

19. WEIGHT

1. Management reserves the right to add or remove weight and/or change percentages on any car at any time in the interest of parity. Cars may be adjusted on an individual basis.
2. Weight measured with driver in seat, race-ready. Minimum total weight 3,000 pounds. No tolerance.
3. Cars with unsealed crate engines or rebuilt crate engines (example: RPM, Hunt’s, etc.) must add 150 lbs. and may be subject to other penalties including additional weight. Weights may be adjusted in the interest of parity.
4. Weights may be adjusted for cars with “homebuilt” engines, in the interest of parity.
5. All added ballast must be made of lead – no other materials permitted.
6. Ballast must be painted white with car number highly visible on ballast in black.
7. Ballast must be 5 lbs. minimum, bolted securely to frame rails and in plain view. All ballast must be located above or between frame rails. No ballast may be hung beyond width of frame rails or below frame. No ballast may be mounted inside car.

IF QUESTIONS, CONTACT:

***John Cummings, Technical Inspector – (802) 265-3408 – Only 6 p.m. to 8 p.m.
Jeremy Carpenter, Technical Inspector – (518) 420-5445 – Text message preferred***

Mike Bruno, Promoter – (802) 236-9141 – Text message preferred

***ALL RULES SUBJECT TO CHANGE WITH OR WITHOUT NOTICE. “EIRI” 2/19/21
Devil’s Bowl Speedway © 2012-2021***

4-Point Roll Cage

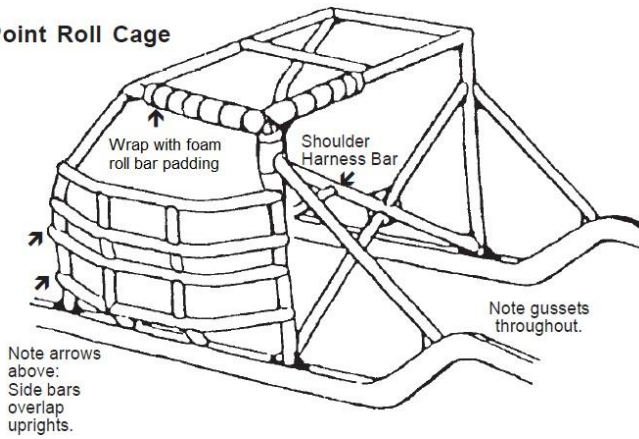

Note arrows above: Side bars overlap uprights.

